

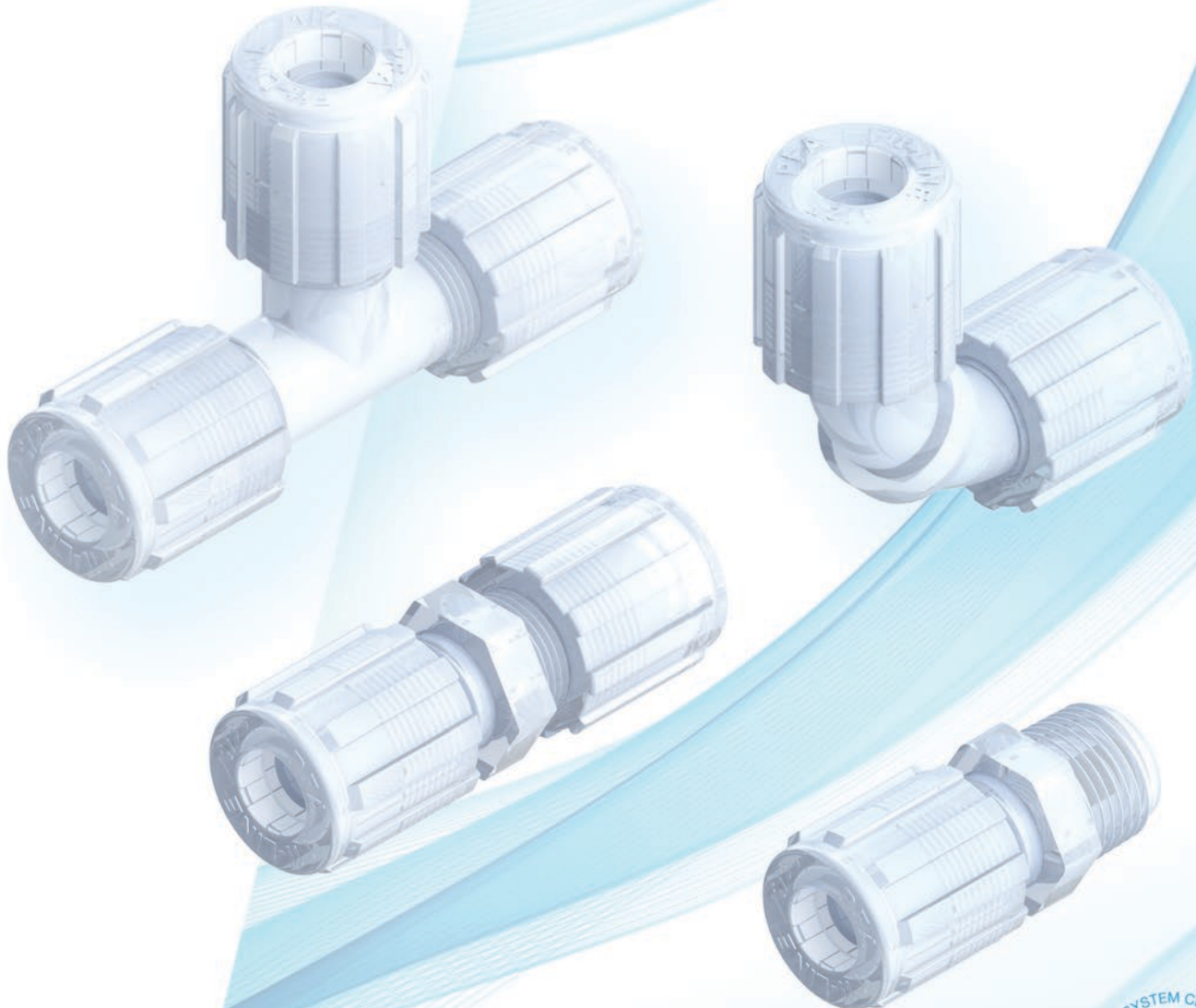

**FIT-LINE**<sup>®</sup>  
GLOBAL

# Flare Link<sup>™</sup>

HIGH PURITY PFA FITTINGS



For more information, please visit: [Fit-LineGlobal.com](http://Fit-LineGlobal.com)



# TABLE OF CONTENTS

|   |    |   |    |
|---|----|---|----|
| Flare Link Introduction . . . . .   | 3  | Male Run Tee (Male Flare x Male Flare x MNPT) . . . . .                       | 30 |
| Pressure vs. Temperature Graphs (PFA Fittings) . . . . .                                | 4  | Male Branch Tee (TightFLARE) (Female Flare x MNPT x Female Flare) . . . . .   | 30 |
| Pressure vs. Temperature Graphs (PVDF Fittings) . . . . .                               | 5  | Male Branch Tee (Male Flare x MNPT x Male Flare) . . . . .                    | 31 |
| Ordering Information—Pipe Thread Connectors/Unions . . . . .                            | 6  | Female Run Tee (Male Flare x Male Flare x FNPT) . . . . .                     | 32 |
| Ordering Information—Weld Connectors/Nuts/Caps & Plugs . . . . .                        | 7  | Female Branch Tee (Male Flare x FNPT x Male Flare) . . . . .                  | 32 |
| Male Connector (Male Flare x MNPT) . . . . .  | 8  | Flare Plug and Nut (Male Flare) . . . . .                                     | 33 |
| Male Connector (TightFLARE) (Female Flare x MNPT) . . . . .                             | 9  | Flare Cap (Female Flare) . . . . .  | 33 |
| Male Connector Panel Mount (Male Flare x MNPT) . . . . .                                | 9  | Flare Nut PFA . . . . .   | 34 |
| Male Connector JIS (Male Flare x JIS) . . . . .   | 10 | Panel Mount Nut (Half Nut) PFA . . . . .                                      | 34 |
| Female Connector (Male Flare x FNPT) . . . . .  | 10 | Reduced Orifice Fittings (Straight Union) (Male Flare x Male Flare) . . . . . | 34 |
| Straight Union (Male Flare x Male Flare) . . . . .                                      | 11 | Reduced Orifice Fittings (Male Connector) (Male Flare x MNPT) . . . . .       | 34 |
| Straight Union Reducer (Male Flare x Male Flare) . . . . .                              | 11 | Pipe Plug . . . . .   | 35 |
| Straight Union (TightFLARE) (Male Flare x Female Flare) . . . . .                       | 11 | Pipe Nipple . . . . .   | 35 |
| Straight Union Panel Mount (Male Flare x Male Flare) . . . . .                          | 12 | Female Male Connector Reducer . . . . .                                       | 35 |
| Straight Union Panel Mount Reducer (Male Flare x Male Flare) . . . . .                  | 12 | GrabLOC Double Containment Fittings (Non-Terminating) . . . . .               | 36 |
| TightFLARE Union (Female Flare x Female Flare) . . . . .                                | 13 | GrabLOC Double Containment Fittings (Terminating) . . . . .                   | 37 |
| Flared PFA Tube Union (Female Flare x Female Flare) . . . . .                           | 13 | GrabLOC Double Containment Tee . . . . .                                      | 38 |
| TightFLARE Male Reducer (Female Flare x Male Flare) . . . . .                           | 14 | Weld Straight Connector (Pipe x Male Flare) . . . . .                         | 39 |
| TightFLARE Female Reducer (Female Flare x Female Flare) . . . . .                       | 15 | Weld Straight Connector (TightFLARE) (Pipe x Female Flare) . . . . .          | 39 |
| TightFLARE Male Increaser (Female Flare x Male Flare) . . . . .                         | 15 | Weld Elbow Connector (Pipe x Male Flare) . . . . .                            | 40 |
| Male Elbow (Male Flare x MNPT) . . . . .  | 16 | Weld Elbow Connector (TightFLARE) (Pipe x Female Flare) . . . . .             | 40 |
| Male Elbow (TightFLARE) (Female Flare x MNPT) . . . . .                                 | 16 | Weld Straight Reducer (Pipe x Pipe) . . . . .                                 | 41 |
| Male Elbow JIS (Male Flare x Metric Pipe) . . . . .                                     | 17 | Weld Pipe Cap (Pipe) . . . . .  | 41 |
| Female Elbow (Male Flare x FNPT) . . . . .  | 17 | Weld Union Elbow (Pipe x Pipe) . . . . .                                      | 42 |
| Union Elbow (Male Flare x Male Flare) . . . . .   | 18 | Weld Union Tee (Pipe x Pipe) . . . . .  | 42 |
| Union Elbow Reducer (Male Flare x Male Flare) . . . . .                                 | 18 | Weld Male Adapter (Pipe x MNPT) . . . . .                                     | 43 |
| Union Elbow Panel Mount (Male Flare x Male Flare) . . . . .                             | 19 | Weld Female Adapter (Pipe x FNPT) . . . . .                                   | 43 |
| Union Elbow (TightFLARE) (Male Flare x Female Flare) . . . . .                          | 19 | Weld Straight Reducer (Tube x Tube) . . . . .                                 | 44 |
| Union Elbow (TightFLARE) (Female Flare x Female Flare) . . . . .                        | 20 | Weld Elbow (Tube x Tube) . . . . .  | 44 |
| Union Elbow Reducer (TightFLARE) (Female Flare x Female Flare) . . . . .                | 20 | Weld Elbow Reducer (Tube x Tube) . . . . .                                    | 45 |
| Union Elbow Sweep (Male Flare x Male Flare) . . . . .                                   | 21 | Weld Elbow Sweep (Tube x Tube) . . . . .                                      | 45 |
| Union Elbow Sweep (TightFLARE) (Male Flare x Female Flare) . . . . .                    | 21 | Weld Tee (Tube x Tube x Tube) . . . . .                                       | 46 |
| Union Elbow Sweep (TightFLARE) (Female Flare x Female Flare) . . . . .                  | 22 | Weld Tee Reducer (Tube x Tube x Tube) . . . . .                               | 46 |
| Male Elbow Sweep (Male Flare x MNPT) . . . . .  | 22 | Weld Cross (All Tube) . . . . .   | 47 |
| Male Elbow Sweep (TightFLARE) (Female Flare x Male Flare) . . . . .                     | 23 | Weld Cross Reducer (All Tube) . . . . .                                       | 47 |
| Union Tee (Male Flare x Male Flare x Male Flare) . . . . .                              | 23 | Flare Link Tube Assembly System . . . . .                                     | 48 |
| Union Tee Reducer (Male Flare x Male Flare x Male Flare) . . . . .                      | 24 | Flare Link Torque Wrench System . . . . .                                     | 49 |
| Union Tee (TightFLARE) Branch (Male Flare x Female Flare x Male Flare) . . . . .        | 25 | Flare Link Torque Wrench System Operating Instructions . . . . .              | 50 |
| Union Tee (TightFLARE) Run (Male Flare x Male Flare x Female Flare) . . . . .           | 26 | WELDED Systems Fabricated Manifolds . . . . .                                 | 51 |
| Union Tee (TightFLARE) Branch, Run (Male Flare x Female Flare x Female Flare) . . . . . | 27 | The Fit-Line Global Story . . . . .   | 52 |
| Union Tee (TightFLARE) Run, Run (Female Flare x Male Flare x Female Flare) . . . . .    | 28 | Warranty & Goods . . . . .  | 54 |
| Union Tee (TightFLARE) All (Female Flare x Female Flare x Female Flare) . . . . .       | 29 |   |    |



# Flare Link™

For over 30 years, Fit-Line Global has designed and manufactured a wide range for PFA flare fittings that are SEMI F57-O622 compliant.

## FEATURES AND BENEFITS

- **High Purity Components**  
All wetted components are molded from virgin ultra high purity PFA material and cleaned using a proprietary 5-stage washing system within a certified class 1000 clean room.
- **Ease of Assembly**  
Our innovative Tube Assembly System and Flare Link torque wrenches allow for consistent flare fitting connections. Refer to pages [48–50](#) for more information.
- **Packaging**  
Each fitting is double poly bagged inside a certified class 1000 clean room per SEMI F57-O622.
- **Traceability**  
Fittings are traceable from raw material, manufacturing to packaging, per SEMI F57-O622. Each fitting is labeled with part number, description, and lot number.

## SEMICONDUCTOR APPLICATIONS

- Bulk chemical and slurry delivery
- Chemical and slurry blend and distribution
- Chemical-Mechanical Polishing (CMP)
- High-temperature wet deaning processes
- Photolithography
- Wet etching

ACCEPTABLE OPERATING RANGE

**PFA Fittings  
Pressure vs. Temperature**

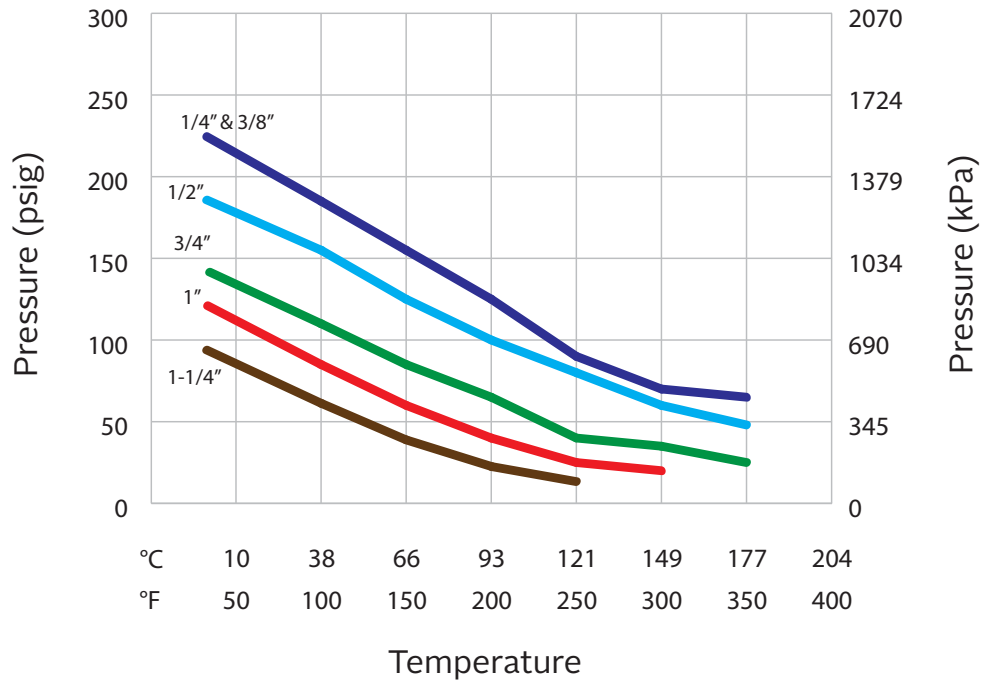

Pressure ratings based on the following tube wall thickness:

| Flare Size | Tube Wall Thickness |
|------------|---------------------|
| 1/4"       | .047"               |
| 3/8"       | .063"               |
| 1/2"       | .063"               |
| 3/4"       | .063"               |
| 1"         | .063"               |
| 1-1/4"     | .075"               |

ACCEPTABLE OPERATING RANGE

### PVDF Fittings Pressure vs. Temperature

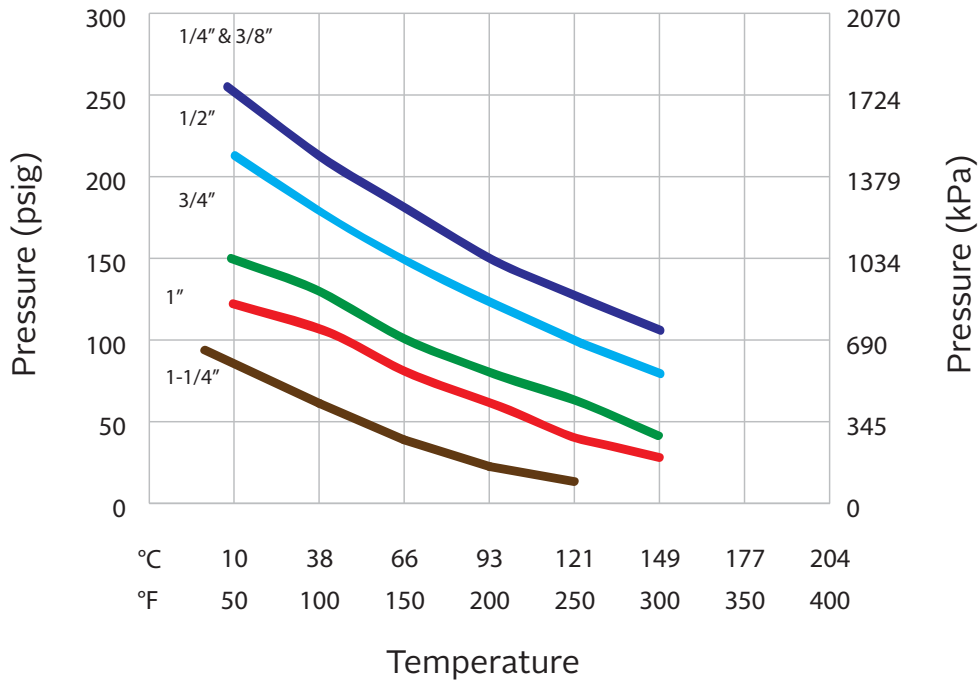

Pressure ratings based on the following tube wall thickness:

| Flare Size | Tube Wall Thickness |
|------------|---------------------|
| 1/4"       | .047"               |
| 3/8"       | .063"               |
| 1/2"       | .063"               |
| 3/4"       | .063"               |
| 1"         | .063"               |
| 1-1/4"     | .075"               |

**WARNING: PVDF not for use in applications exceeding 248° F (120° C)**

Fit-Line Global is not responsible for product damage due to accidents, misuse, or improper application usage.

PIPE THREAD CONNECTORS:

FBT 8 8 - 8 N - 3

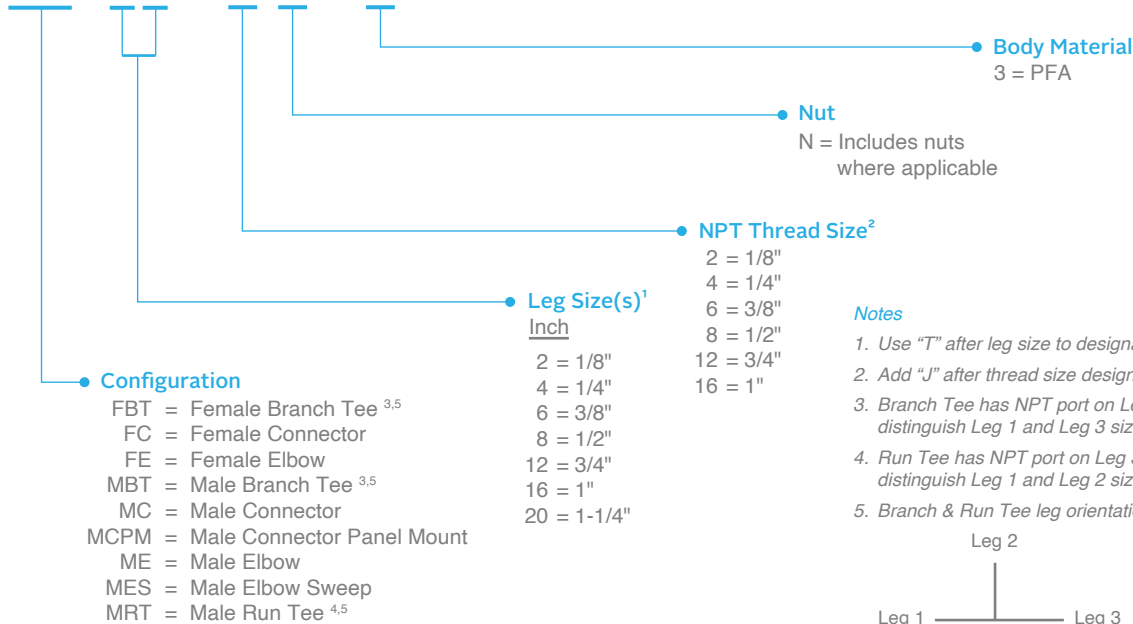

Notes

1. Use "T" after leg size to designate female connection.
2. Add "J" after thread size designator for JIS taper thread.
3. Branch Tee has NPT port on Leg 2. Size designators distinguish Leg 1 and Leg 3 sizes, respectively.
4. Run Tee has NPT port on Leg 3. Size designators distinguish Leg 1 and Leg 2 sizes, respectively.
5. Branch & Run Tee leg orientation:



UNIONS:

SU 8 8 N - 3

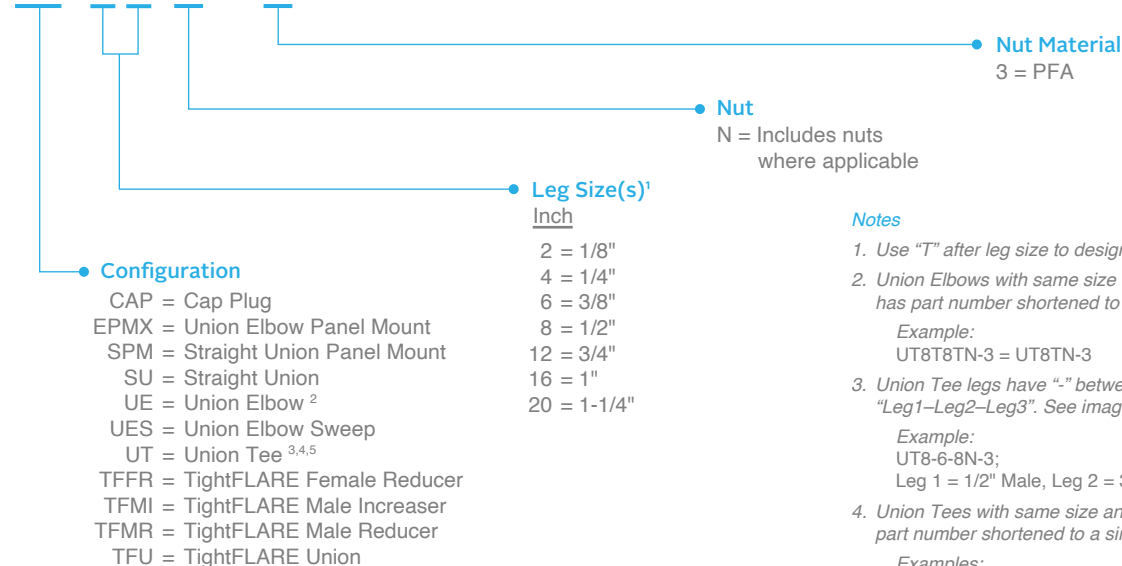

Notes

1. Use "T" after leg size to designate female connection.
2. Union Elbows with same size female connection on both sides has part number shortened to a single leg size descriptor.  
 Example:  
 UT8T8TN-3 = UT8TN-3
3. Union Tee legs have "-" between size designators in sequence: "Leg1-Leg2-Leg3". See image below for reference<sup>5</sup>.  
 Example:  
 UT8-6-8N-3;  
 Leg 1 = 1/2" Male, Leg 2 = 3/8" Male, Leg 3 = 1/2" Male
4. Union Tees with same size and type connection on all sides has part number shortened to a single leg size descriptor.  
 Examples:  
 UT8-8-8N-3 = UT8N-3  
 UT8T-8T-8TN-3 = UT8TN-3
5. Union Tee leg orientation:



WELD CONNECTORS:

WEC 8 P - 8 N - 3

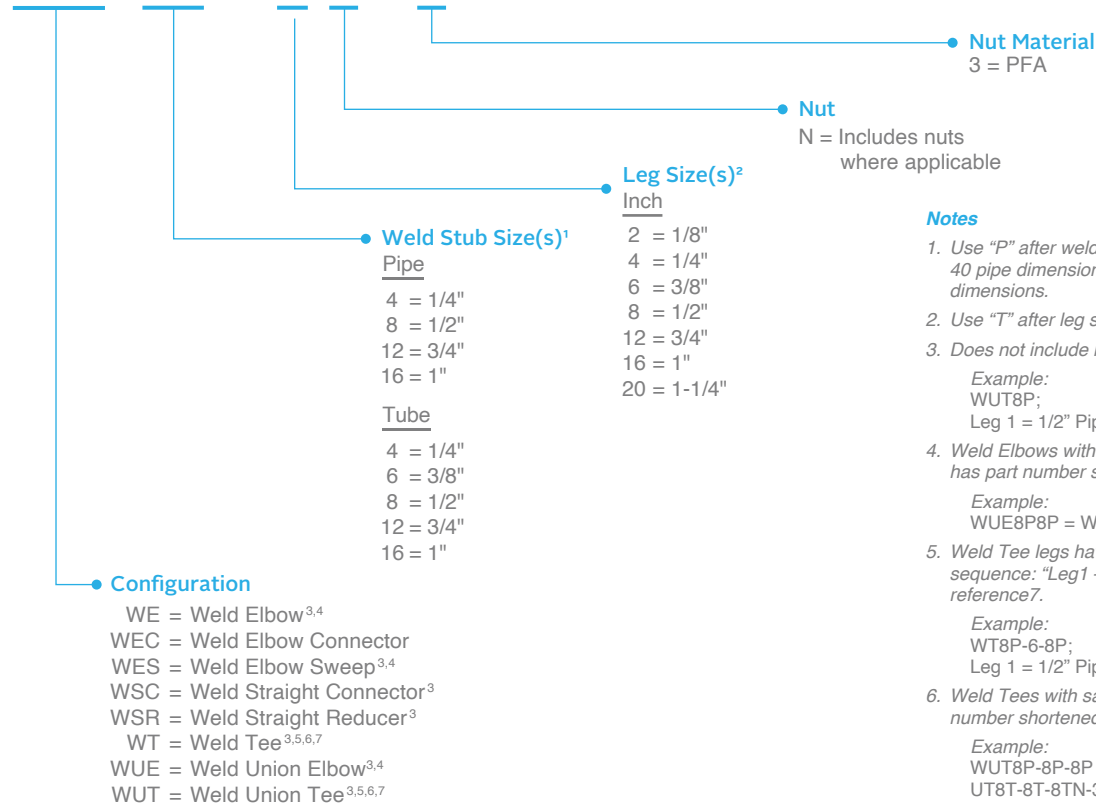

**Notes**

- Use "P" after weld stub size to designate schedule 40 pipe dimensions, or "TS" to designate tube straight dimensions.
- Use "T" after leg size to designate female connection.
- Does not include nuts, omit "N-#" from p/n:  
 Example:  
 WUT8P;  
 Leg 1 = 1/2" Pipe, Leg 2 = 1/2" Pipe, Leg 3 = 1/2" Pipe
- Weld Elbows with the same size connection on both sides has part number shortened to a single leg size descriptor.  
 Example:  
 WUE8P8P = WUE8P
- Weld Tee legs have "-" between size designators in sequence: "Leg1 - Leg2 - Leg3". See image below for reference<sup>7</sup>.  
 Example:  
 WT8P-6-8P;  
 Leg 1 = 1/2" Pipe, Leg 2 = 3/8" Male, Leg 3 = 1/2" Pipe
- Weld Tees with same size connection on all sides has part number shortened to a single leg size descriptor.  
 Example:  
 WUT8P-8P-8P = WUT8P  
 UT8T-8T-8TN-3 = UT8TN-3
- Weld Tee leg orientation:



NUTS:

N 8 - 3

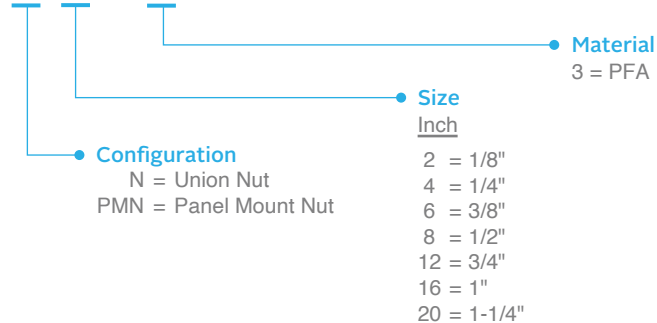

CAPS & PLUGS:

FCAP 4

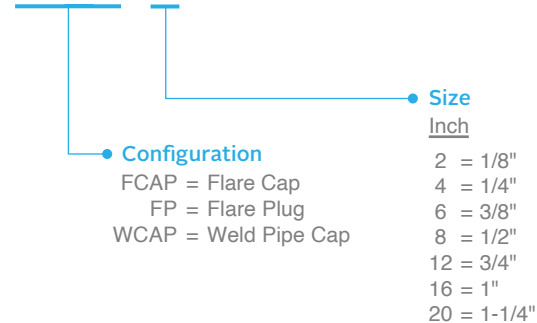

**Male Connector**  
(Male Flare x MNPT)

| PFA Part No. | Tube O.D. | MNPT Size | Orifice | A    | B    | C   | Hex    |
|--------------|-----------|-----------|---------|------|------|-----|--------|
| MC4-2N-3     | 1/4       | 1/8       | .15     | 1.91 | .97  | .45 | 5/8    |
| MC4-4N-3     | 1/4       | 1/4       | .15     | 2.00 | .97  | .55 | 5/8    |
| MC4-6N-3     | 1/4       | 3/8       | .15     | 2.00 | .97  | .55 | 11/16  |
| MC4-8N-3     | 1/4       | 1/2       | .15     | 2.12 | .97  | .66 | 13/16  |
| MC4-12N-3    | 1/4       | 3/4       | .15     | 2.12 | .97  | .67 | 1-3/16 |
| MC4-16N-3    | 1/4       | 1         | .15     | 2.32 | .97  | .85 | 1-7/16 |
| MC6-2N-3     | 3/8       | 1/8       | .18     | 2.10 | 1.04 | .54 | 13/16  |
| MC6-4N-3     | 3/8       | 1/4       | .25     | 2.11 | 1.04 | .55 | 13/16  |
| MC6-6N-3     | 3/8       | 3/8       | .25     | 2.11 | 1.04 | .55 | 13/16  |
| MC6-8N-3     | 3/8       | 1/2       | .25     | 2.23 | 1.04 | .66 | 15/16  |
| MC6-12N-3    | 3/8       | 3/4       | .25     | 2.22 | 1.04 | .66 | 1-3/16 |
| MC6-16N-3    | 3/8       | 1         | .25     | 2.39 | 1.04 | .85 | 1-7/16 |
| MC8-2N-3     | 1/2       | 1/8       | .18     | 2.20 | 1.14 | .54 | 15/16  |
| MC8-4N-3     | 1/2       | 1/4       | .38     | 2.20 | 1.14 | .55 | 15/16  |
| MC8-6N-3     | 1/2       | 3/8       | .38     | 2.20 | 1.14 | .55 | 15/16  |
| MC8-8N-3     | 1/2       | 1/2       | .38     | 2.32 | 1.14 | .66 | 15/16  |
| MC8-12N-3    | 1/2       | 3/4       | .38     | 2.32 | 1.14 | .66 | 1-3/16 |
| MC8-16N-3    | 1/2       | 1         | .38     | 2.51 | 1.14 | .86 | 1-7/16 |
| MC12-6N-3    | 3/4       | 3/8       | .38     | 2.37 | 1.29 | .56 | 15-16  |
| MC12-8N-3    | 3/4       | 1/2       | .51     | 2.48 | 1.29 | .67 | 1-3/16 |
| MC12-12N-3   | 3/4       | 3/4       | .63     | 2.48 | 1.29 | .67 | 1-3/16 |
| MC12-16N-3   | 3/4       | 1         | .63     | 2.66 | 1.29 | .85 | 1-7/16 |
| MC16-8N-3    | 1         | 1/2       | .51     | 2.69 | 1.46 | .67 | 1-7/16 |
| MC16-12N-3   | 1         | 3/4       | .66     | 2.69 | 1.46 | .67 | 1-7/16 |
| MC16-16N-3   | 1         | 1         | .88     | 2.88 | 1.46 | .86 | 1-7/16 |
| MC20-16N-3   | 1-1/4     | 1         | .97     | 3.29 | 1.75 | .86 | 1-3/4  |
| MC20-20N-3   | 1-1/4     | 1-1/4     | 1.10    | 3.29 | 1.75 | .86 | 1-3/4  |

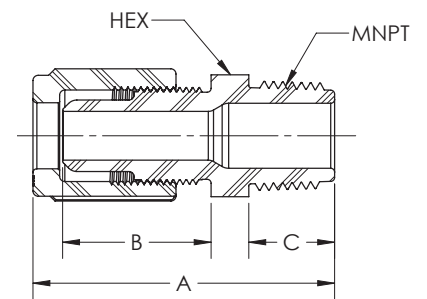

### Male Connector (TightFLARE) (Female Flare x MNPT)

| PFA Part No. | TightFLARE | MNPT Size | Orifice | A    | B   | C   | Hex    |
|--------------|------------|-----------|---------|------|-----|-----|--------|
| MC4T-2N-3    | 1/4        | 1/8       | .15     | 1.81 | .25 | .45 | 5/8    |
| MC4T-4N-3    | 1/4        | 1/4       | .15     | 2.13 | .53 | .55 | 5/8    |
| MC4T-6N-3    | 1/4        | 3/8       | .15     | 2.13 | .53 | .55 | 11/16  |
| MC4T-8N-3    | 1/4        | 1/2       | .15     | 2.27 | .53 | .67 | 13/16  |
| MC6T-4N-3    | 3/8        | 1/4       | .25     | 2.22 | .52 | .56 | 13/16  |
| MC6T-6N-3    | 3/8        | 3/8       | .25     | 2.22 | .53 | .55 | 13/16  |
| MC6T-8N-3    | 3/8        | 1/2       | .25     | 2.33 | .52 | .67 | 13/16  |
| MC8T-4N-3    | 1/2        | 1/4       | .25     | 2.28 | .53 | .56 | 15/16  |
| MC8T-6N-3    | 1/2        | 3/8       | .38     | 2.26 | .53 | .55 | 13/16  |
| MC8T-8N-3    | 1/2        | 1/2       | .38     | 2.47 | .53 | .67 | 15/16  |
| MC12T-8N-3   | 3/4        | 1/2       | .51     | 2.57 | .56 | .67 | 1-3/16 |
| MC12T-12N-3  | 3/4        | 3/4       | .63     | 2.57 | .56 | .67 | 1-3/16 |
| MC12T-16N-3  | 3/4        | 1         | .63     | 2.76 | .56 | .86 | 1-7/16 |
| MC16T-16N-3  | 1          | 1         | .88     | 2.99 | .50 | .86 | 1-7/16 |

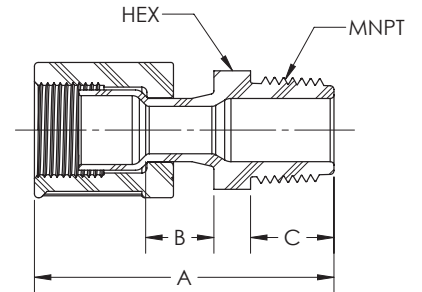

### Male Connector Panel Mount (Male Flare x MNPT)

| PFA Part No. | Tube O.D. | MNPT Size | Orifice | A    | B    | C   | D (Max) | Hex 1  | Hex 2  | Min Panel Hole Dia |
|--------------|-----------|-----------|---------|------|------|-----|---------|--------|--------|--------------------|
| MCPM4-2N-3   | 1/4       | 1/8       | .15     | 2.78 | 1.73 | .55 | .50     | 3/4    | 11/16  | 1/2                |
| MCPM4-4N-3   | 1/4       | 1/4       | .15     | 2.78 | 1.73 | .55 | .50     | 3/4    | 11/16  | 1/2                |
| MCPM4-6N-3   | 1/4       | 3/8       | .15     | 2.78 | 1.73 | .55 | .50     | 3/4    | 11/16  | 1/2                |
| MCPM6-4N-3   | 3/8       | 1/4       | .25     | 2.87 | 1.83 | .55 | .50     | 15/16  | 13/16  | 5/8                |
| MCPM6-6N-3   | 3/8       | 3/8       | .25     | 2.87 | 1.83 | .55 | .50     | 15/16  | 13/16  | 5/8                |
| MCPM8-4N-3   | 1/2       | 1/4       | .38     | 2.99 | 1.94 | .55 | .50     | 1-1/16 | 15/16  | 3/4                |
| MCPM8-6N-3   | 1/2       | 3/8       | .38     | 2.99 | 1.94 | .55 | .50     | 1-1/16 | 15/16  | 3/4                |
| MCPM8-8N-3   | 1/2       | 1/2       | .38     | 3.10 | 1.94 | .67 | .50     | 1-1/16 | 15/16  | 3/4                |
| MCPM12-12N-3 | 3/4       | 3/4       | .63     | 3.26 | 2.06 | .68 | .50     | 1-5/16 | 1-3/16 | 1                  |
| MCPM16-16N-3 | 1         | 1         | .88     | 3.66 | 2.21 | .86 | .50     | 1-3/4  | 1-5/8  | 1-7/16             |

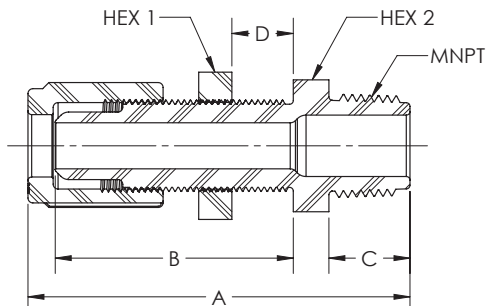

| Male Connector JIS<br>(Male Flare x JIS) |           |          |         |      |      |     |        |
|--|-----------|----------|---------|------|------|-----|--------|
| PFA Part No.                             | Tube O.D. | JIS Size | Orifice | A    | B    | C   | Hex    |
| MC4-4JN-3                                | 1/4       | 1/4      | .15     | 2.00 | .97  | .56 | 5/8    |
| MC4-6JN-3                                | 1/4       | 3/8      | .15     | 2.00 | .97  | .56 | 11/16  |
| MC4-8JN-3                                | 1/4       | 1/2      | .15     | 2.11 | .97  | .66 | 15/16  |
| MC6-4JN-3                                | 3/8       | 1/4      | .25     | 2.11 | 1.04 | .56 | 13/16  |
| MC6-6JN-3                                | 3/8       | 3/8      | .25     | 2.11 | 1.04 | .56 | 13/16  |
| MC6-8JN-3                                | 3/8       | 1/2      | .25     | 2.22 | 1.04 | .67 | 15/16  |
| MC8-4JN-3                                | 1/2       | 1/4      | .38     | 2.20 | 1.14 | .56 | 15/16  |
| MC8-6JN-3                                | 1/2       | 3/8      | .38     | 2.20 | 1.14 | .56 | 15/16  |
| MC8-8JN-3                                | 1/2       | 1/2      | .38     | 2.32 | 1.14 | .67 | 15/16  |
| MC8-12JN-3                               | 1/2       | 3/4      | .38     | 2.32 | 1.14 | .68 | 1-3/16 |
| MC12-6JN-3                               | 3/4       | 3/8      | .63     | 2.37 | 1.29 | .56 | 1-3/16 |
| MC12-8JN-3                               | 3/4       | 1/2      | .51     | 2.48 | 1.29 | .67 | 1-3/16 |
| MC12-12JN-3                              | 3/4       | 3/4      | .63     | 2.49 | 1.29 | .67 | 1-3/16 |
| MC12-16JN-3                              | 3/4       | 1        | .63     | 2.65 | 1.29 | .85 | 1-7/16 |
| MC16-12JN-3                              | 1         | 3/4      | .66     | 2.69 | 1.46 | .67 | 1-7/16 |
| MC16-16JN-3                              | 1         | 1        | .88     | 2.87 | 1.46 | .85 | 1-7/16 |

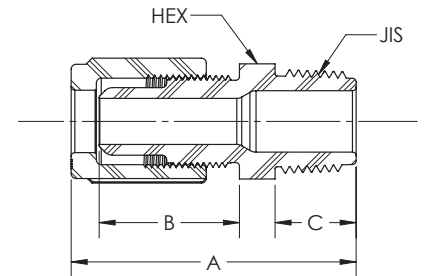

| Female Connector<br>(Male Flare x FNPT) |           |           |         |      |      |      |       |
|---|-----------|-----------|---------|------|------|------|-------|
| PFA Part No.                            | Tube O.D. | FNPT Size | Orifice | A    | B    | C    | Hex   |
| FC4-2N-3                                | 1/4       | 1/8       | .15     | 1.90 | .97  | .79  | 5/8   |
| FC4-4N-3                                | 1/4       | 1/4       | .15     | 1.99 | .97  | .84  | 3/4   |
| FC4-6N-3                                | 1/4       | 3/8       | .15     | 2.00 | .97  | .92  | 15/16 |
| FC4-8N-3                                | 1/4       | 1/2       | .15     | 2.02 | .97  | .86  | 1-1/8 |
| FC6-2N-3                                | 3/8       | 1/8       | .25     | 1.78 | 1.04 | .74  | 5/8   |
| FC6-4N-3                                | 3/8       | 1/4       | .25     | 2.05 | 1.04 | .84  | 3/4   |
| FC6-6N-3                                | 3/8       | 3/8       | .25     | 2.10 | 1.04 | .84  | 15/16 |
| FC6-8N-3                                | 3/8       | 1/2       | .25     | 2.13 | 1.04 | .86  | 1-1/8 |
| FC8-4N-3                                | 1/2       | 1/4       | .38     | 2.18 | 1.14 | .84  | 3/4   |
| FC8-6N-3                                | 1/2       | 3/8       | .38     | 2.20 | 1.14 | .87  | 15/16 |
| FC8-8N-3                                | 1/2       | 1/2       | .38     | 2.22 | 1.14 | .86  | 1-1/8 |
| FC8-12N-3                               | 1/2       | 3/4       | .38     | 2.28 | 1.14 | .92  | 1-3/8 |
| FC8-16N-3                               | 1/2       | 1         | .38     | 2.50 | 1.14 | 1.14 | 1-5/8 |
| FC12-8N-3                               | 3/4       | 1/2       | .63     | 2.38 | 1.29 | .86  | 1-1/8 |
| FC12-12N-3                              | 3/4       | 3/4       | .63     | 2.44 | 1.29 | .92  | 1-3/8 |
| FC12-16N-3                              | 3/4       | 1         | .63     | 2.66 | 1.29 | 1.14 | 1-5/8 |
| FC16-16N-3                              | 1         | 1         | .88     | 2.88 | 1.46 | 1.14 | 1-5/8 |

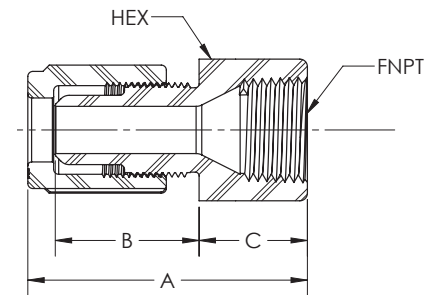

| Straight Union<br>(Male Flare x Male Flare) |           |         |      |      |        |
|---|-----------|---------|------|------|--------|
| PFA Part No.                                | Tube O.D. | Orifice | A    | B    | Hex    |
| SU44N-3                                     | 1/4       | .15     | 2.62 | .97  | 11/16  |
| SU66N-3                                     | 3/8       | .25     | 2.83 | 1.04 | 13/16  |
| SU88N-3                                     | 1/2       | .38     | 3.02 | 1.14 | 15/16  |
| SU1212N-3                                   | 3/4       | .63     | 3.32 | 1.29 | 1-3/16 |
| SU1616N-3                                   | 1         | .88     | 3.72 | 1.46 | 1-7/16 |
| SU2020N-3                                   | 1-1/4     | 1.10    | 4.88 | 1.75 | 1-3/4  |

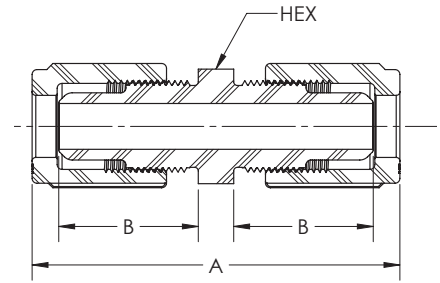

| Straight Union Reducer<br>(Male Flare x Male Flare) |           |           |      |      |      |        |
|---|-----------|-----------|------|------|------|--------|
| PFA Part No.  | Tube O.D. | Tube O.D. | A    | B    | C    | Hex    |
| SU64N-3   | 3/8       | 1/4       | 2.72 | 1.04 | .97  | 11/16  |
| SU84N-3   | 1/2       | 1/4       | 2.82 | 1.14 | .97  | 15/16  |
| SU86N-3   | 1/2       | 3/8       | 2.92 | 1.14 | 1.04 | 15/16  |
| SU124N-3  | 3/4       | 1/4       | 2.96 | 1.29 | .97  | 1-3/16 |
| SU126N-3  | 3/4       | 3/8       | 3.07 | 1.29 | 1.05 | 1-3/16 |
| SU128N-3  | 3/4       | 1/2       | 3.17 | 1.29 | 1.14 | 1-3/16 |
| SU164N-3  | 1         | 1/4       | 3.17 | 1.46 | .97  | 1-7/16 |
| SU166N-3  | 1         | 3/8       | 3.30 | 1.46 | 1.04 | 1-7/16 |
| SU168N-3  | 1         | 1/2       | 3.38 | 1.45 | 1.14 | 1-7/16 |
| SU1612N-3   | 1         | 3/4       | 3.53 | 1.46 | 1.29 | 1-7/16 |
| SU2016N-3   | 1-1/4     | 1         | 4.36 | 1.75 | 1.51 | 1-3/4  |

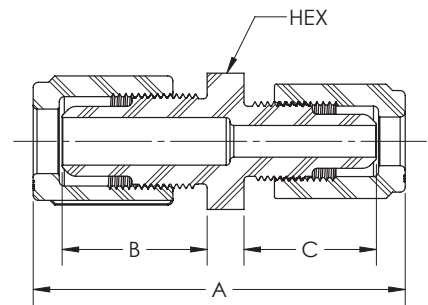

| Straight Union (TightFLARE)<br>(Male Flare x Female Flare) |                        |         |      |      |     |        |
|--|------------------------|---------|------|------|-----|--------|
| PFA Part No.   | Tube O.D. / TightFLARE | Orifice | A    | B    | C   | Hex    |
| SU44TN-3   | 1/4                    | .15     | 2.76 | .97  | .53 | 11/16  |
| SU66TN-3   | 3/8                    | .25     | 2.93 | 1.04 | .52 | 13/16  |
| SU88TN-3   | 1/2                    | .38     | 3.07 | 1.14 | .51 | 15/16  |
| SU1212TN-3   | 3/4                    | .63     | 3.41 | 1.29 | .56 | 1-3/16 |
| SU1616TN-3   | 1                      | .88     | 4.04 | 1.46 | .50 | 1-7/16 |

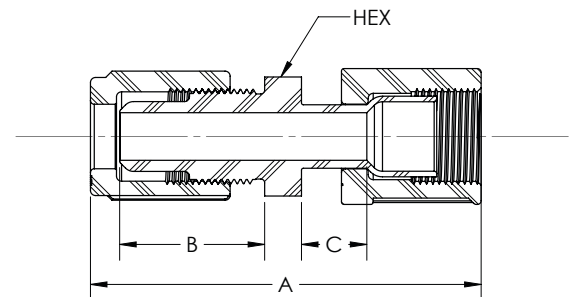

| Straight Union Panel Mount<br>(Male Flare x Male Flare) |               |           |         |      |      |      |         |        |        |                    |
|---|---------------|-----------|---------|------|------|------|---------|--------|--------|--------------------|
| PFA Part No.  | PVDF Part No. | Tube O.D. | Orifice | A    | B    | C    | D (Max) | Hex 1  | Hex 2  | Min Panel Hole Dia |
| SPM44N-3  | SPM44         | 1/4       | .15     | 3.40 | 1.73 | .97  | .50     | 3/4    | 11/16  | 1/2                |
| SPM66N-3  | SPM66         | 3/8       | .25     | 3.58 | 1.83 | 1.04 | .50     | 15/16  | 13/16  | 5/8                |
| SPM88N-3  | SPM88         | 1/2       | .38     | 3.80 | 1.94 | 1.14 | .50     | 1-1/16 | 15/16  | 3/4                |
| SPM1212N-3  | SPM1212       | 3/4       | .63     | 4.11 | 2.06 | 1.29 | .50     | 1-5/16 | 1-3/16 | 1                  |
| SPM1616N-3  | SPM1616       | 1         | .88     | 4.53 | 2.21 | 1.46 | .50     | 1-3/4  | 1-5/8  | 1-7/16             |

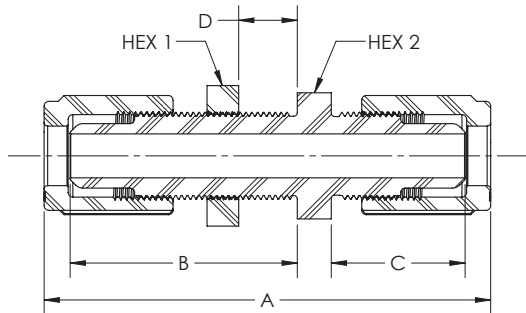

| Straight Union Panel Mount Reducer<br>(Male Flare x Male Flare) |           |           |         |      |      |      |         |        |        |                    |
|---|-----------|-----------|---------|------|------|------|---------|--------|--------|--------------------|
| PFA Part No.  | Tube O.D. | Tube O.D. | Orifice | A    | B    | C    | D (Max) | Hex 1  | Hex 2  | Min Panel Hole Dia |
| SPM64N-3  | 3/8       | 1/4       | .15     | 3.48 | 1.83 | .97  | .50     | 15/16  | 13/16  | 5/8                |
| SPM84N-3  | 1/2       | 1/4       | .15     | 3.59 | 1.94 | .97  | .50     | 1-1/16 | 15/16  | 3/4                |
| SPM86N-3  | 1/2       | 3/8       | .25     | 3.70 | 1.94 | 1.04 | .50     | 1-1/16 | 15/16  | 3/4                |
| SPM126N-3   | 3/4       | 3/8       | .25     | 3.86 | 2.06 | 1.04 | .50     | 1-5/16 | 1-3/16 | 1                  |
| SPM128N-3   | 3/4       | 1/2       | .38     | 3.95 | 2.06 | 1.14 | .50     | 1-5/16 | 1-3/16 | 1                  |
| SPM1612N-3  | 1         | 3/4       | .63     | 4.31 | 2.21 | 1.29 | .50     | 1-3/4  | 1-5/8  | 1-7/16             |

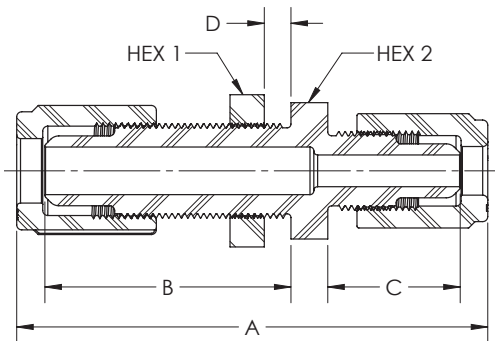

| TightFLARE Union<br>(Female Flare x Female Flare) |            |         |      |      |     |      |
|---|------------|---------|------|------|-----|------|
| PFA Part No.                                      | TightFLARE | Orifice | A    | B    | C   | D    |
| TFU4N-3   | 1/4        | .15     | .84  | 1.03 | .36 | .78  |
| TFU6N-3   | 3/8        | .25     | .86  | 1.10 | .38 | .91  |
| TFU8N-3   | 1/2        | .38     | .93  | 1.15 | .38 | 1.03 |
| TFU12N-3  | 3/4        | .63     | .90  | 1.32 | .38 | 1.35 |
| TFU16N-3  | 1          | .88     | 1.05 | 1.50 | .52 | 1.76 |
| TFU20N-3  | 1-1/4      | 1.10    | 1.03 | 1.83 | .52 | 2.20 |

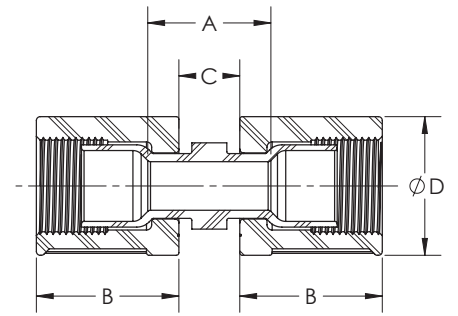

| Flared PFA Tube Union<br>(Female Flare x Female Flare) |            |         |      |      |      |      |
|--|------------|---------|------|------|------|------|
| PFA Nut Part No.                                       | TightFLARE | Orifice | A    | B    | C    | D    |
| FTU4N-3-53   | 1/4        | .15     | .53  | 1.03 | .14  | .78  |
| FTU4N-3-88   | 1/4        | .15     | .88  | 1.03 | .50  | .78  |
| FTU4N-3-336  | 1/4        | .15     | 3.36 | 1.03 | 2.38 | .78  |
| FTU6N-3-51   | 3/8        | .25     | .51  | 1.10 | .13  | .91  |
| FTU6N-3-88   | 3/8        | .25     | .88  | 1.10 | .50  | .91  |
| FTU8N-3-47   | 1/2        | .38     | .47  | 1.15 | .09  | 1.03 |
| FTU8N-3-88   | 1/2        | .39     | .88  | 1.15 | .50  | 1.03 |
| FTU8N-3-269  | 1/2        | .40     | 2.69 | 1.15 | 2.31 | 1.03 |
| FTU8N-3-382  | 1/2        | .41     | 3.82 | 1.15 | 3.44 | 1.03 |
| FTU12N-3-59  | 3/4        | .63     | .59  | 1.32 | .12  | 1.35 |
| FTU12N-3-97  | 3/4        | .63     | .97  | 1.32 | .50  | 1.35 |
| FTU12N-3-378   | 3/4        | .63     | 3.78 | 1.32 | 3.31 | 1.35 |
| FTU16N-3-68  | 1          | .88     | .68  | 1.50 | .15  | 1.76 |
| FTU16N-3-103   | 1          | .88     | 1.03 | 1.50 | .50  | 1.76 |
| FTU16N-3-272   | 1          | .88     | 2.72 | 1.50 | 2.19 | 1.76 |

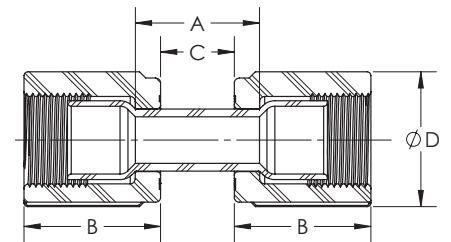

Custom "A" dimensions available upon request. Email: [info@Fit-LineGlobal.com](mailto:info@Fit-LineGlobal.com)

| TightFLARE Male Reducer<br>(Female Flare x Male Flare) |            |           |         |      |
|--|------------|-----------|---------|------|
| PFA Part No.   | TightFLARE | Tube O.D. | Orifice | A    |
| TFMR64N-3  | 3/8        | 1/4       | .15     | 1.13 |
| TFMR84N-3  | 1/2        | 1/4       | .15     | .97  |
| TFMR86N-3  | 1/2        | 3/8       | .25     | 1.21 |
| TFMR124N-3   | 3/4        | 1/4       | .15     | 1.07 |
| TFMR126N-3   | 3/4        | 3/8       | .25     | 1.16 |
| TFMR128N-3   | 3/4        | 1/2       | .38     | 1.24 |
| TFMR164N-3   | 1          | 1/4       | .15     | 1.03 |
| TFMR166N-3   | 1          | 3/8       | .25     | 1.11 |
| TFMR168N-3   | 1          | 1/2       | .38     | 1.20 |
| TFMR1612N-3  | 1          | 3/4       | .63     | 1.31 |
| TFMR204N-3   | 1-1/4      | 1/4       | .15     | 1.07 |
| TFMR206N-3   | 1-1/4      | 3/8       | .25     | 1.16 |
| TFMR208N-3   | 1-1/4      | 1/2       | .38     | 1.24 |
| TFMR2012N-3  | 1-1/4      | 3/4       | .63     | 1.31 |
| TFMR2016N-3  | 1-1/4      | 1         | .88     | 1.75 |

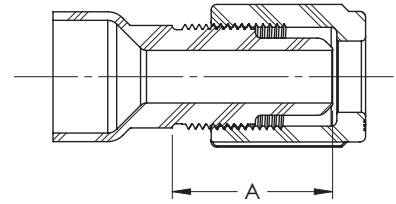

**TIGHTFLARE MALE REDUCER ASSEMBLY**

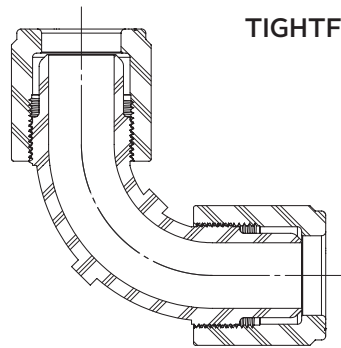

UES1212N-1  
UNION ELBOW SWEEP,  
3/4" FLARE X 3/4" FLARE

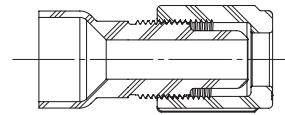

TFMR128N-1  
TightFLARE MALE REDUCER,  
3/4" TightFLARE X 1/2" FLARE

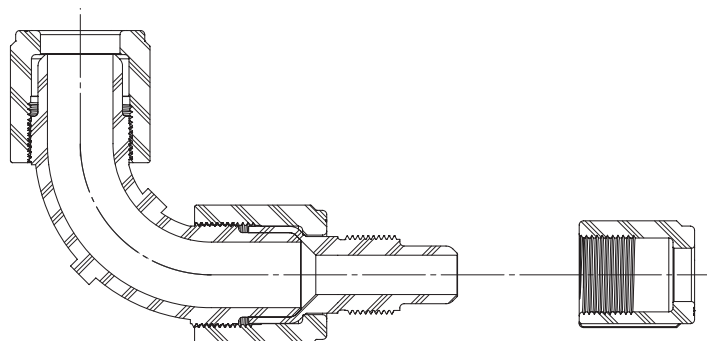

UNION ELBOW SWEEP,  
3/4" FLARE REDUCED TO 1/2" FLARE

| TightFLARE Female Reducer<br>(Female Flare x Female Flare) |              |              |         |     |
|--|--------------|--------------|---------|-----|
| PFA Part No.   | TightFLARE 1 | TightFLARE 2 | Orifice | A   |
| TFFR64N-3  | 3/8          | 1/4          | .15     | .76 |
| TFFR84N-3  | 1/2          | 1/4          | .15     | .80 |
| TFFR86N-3  | 1/2          | 3/8          | .25     | .68 |
| TFFR124N-3   | 3/4          | 1/4          | .15     | .92 |
| TFFR126N-3   | 3/4          | 3/8          | .25     | .68 |
| TFFR128N-3   | 3/4          | 1/2          | .38     | .75 |
| TFFR164N-3   | 1            | 1/4          | .15     | .95 |
| TFFR166N-3   | 1            | 3/8          | .25     | .92 |
| TFFR168N-3   | 1            | 1/2          | .38     | .93 |
| TFFR1612N-3  | 1            | 3/4          | .63     | .95 |

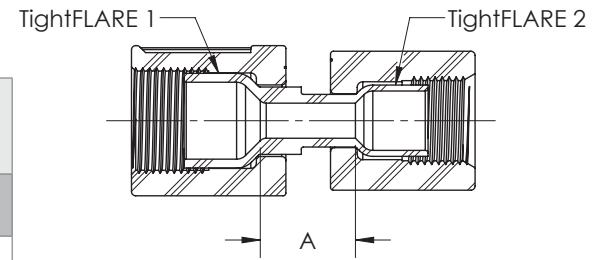

| TightFLARE Male Increaser<br>(Female Flare x Male Flare) |            |           |         |      |     |      |        |
|--|------------|-----------|---------|------|-----|------|--------|
| PFA Part No.   | TightFLARE | Tube O.D. | Orifice | A    | B   | C    | Hex    |
| TFMI46N-3  | 1/4        | 3/8       | .15     | 2.88 | .53 | 1.04 | 13/16  |
| TFMI48N-3  | 1/4        | 1/2       | .15     | 2.97 | .53 | 1.14 | 15/16  |
| TFMI68N-3  | 3/8        | 1/2       | .25     | 3.03 | .52 | 1.14 | 15/16  |
| TFMI612N-3   | 3/8        | 3/4       | .25     | 3.19 | .52 | 1.29 | 1-3/16 |
| TFMI812N-3   | 1/2        | 3/4       | .38     | 3.23 | .53 | 1.29 | 1-3/16 |
| TFMI816N-3   | 1/2        | 1         | .38     | 3.44 | .53 | 1.46 | 1-7/16 |
| TFMI1216N-3  | 3/4        | 1         | .63     | 3.66 | .56 | 1.46 | 1-7/16 |
| TFMI1620N-3  | 1          | 1-1/4     | .88     | 4.39 | .46 | 1.75 | 1-3/4  |

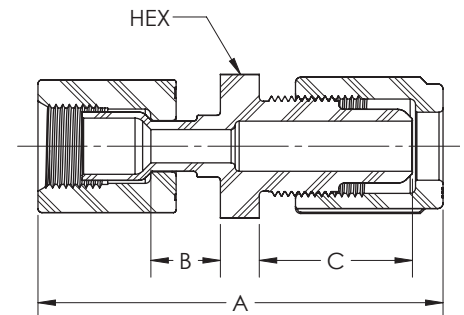

| Male Elbow<br>(Male Flare x MNPT) |           |           |         |      |      |      |
|-----------------------------------|-----------|-----------|---------|------|------|------|
| PFA Part No.                      | Tube O.D. | MNPT Size | Orifice | A    | B    | C    |
| ME4-2N-3                          | 1/4       | 1/8       | .15     | 1.66 | 1.47 | 1.06 |
| ME4-4N-3                          | 1/4       | 1/4       | .15     | 1.66 | 1.47 | 1.06 |
| ME4-6N-3                          | 1/4       | 3/8       | .15     | 1.66 | 1.47 | 1.06 |
| ME4-8N-3                          | 1/4       | 1/2       | .15     | 1.66 | 1.47 | 1.17 |
| ME6-2N-3                          | 3/8       | 1/8       | .18     | 1.76 | 1.53 | 1.06 |
| ME6-4N-3                          | 3/8       | 1/4       | .25     | 1.76 | 1.53 | 1.06 |
| ME6-6N-3                          | 3/8       | 3/8       | .25     | 1.76 | 1.53 | 1.06 |
| ME6-8N-3                          | 3/8       | 1/2       | .25     | 1.76 | 1.53 | 1.18 |
| ME6-12N-3                         | 3/8       | 3/4       | .25     | 1.76 | 1.53 | 1.36 |
| ME8-2N-3                          | 1/2       | 1/8       | .18     | 1.86 | 1.64 | 1.06 |
| ME8-4N-3                          | 1/2       | 1/4       | .25     | 1.86 | 1.64 | 1.06 |
| ME8-6N-3                          | 1/2       | 3/8       | .38     | 1.86 | 1.64 | 1.06 |
| ME8-8N-3                          | 1/2       | 1/2       | .38     | 1.86 | 1.64 | 1.18 |
| ME8-12N-3                         | 1/2       | 3/4       | .49     | 1.86 | 1.64 | 1.36 |
| ME8-16N-3                         | 1/2       | 1         | .38     | 1.86 | 1.64 | 1.80 |
| ME12-6N-3                         | 3/4       | 3/8       | .36     | 2.21 | 1.98 | 1.23 |
| ME12-8N-3                         | 3/4       | 1/2       | .53     | 2.21 | 1.98 | 1.36 |
| ME12-12N-3                        | 3/4       | 3/4       | .63     | 2.21 | 1.98 | 1.37 |
| ME12-16N-3                        | 3/4       | 1         | .63     | 2.21 | 1.98 | 1.80 |
| ME16-8N-3                         | 1         | 1/2       | .51     | 2.70 | 2.43 | 1.37 |
| ME16-12N-3                        | 1         | 3/4       | .66     | 2.70 | 2.43 | 1.64 |
| ME16-16N-3                        | 1         | 1         | .87     | 2.70 | 2.43 | 1.80 |

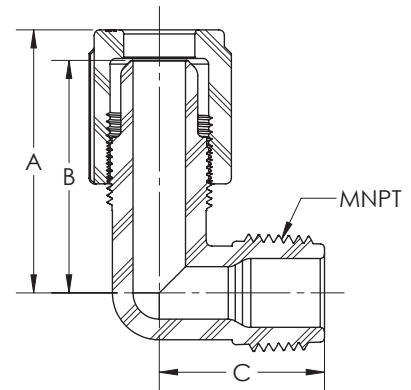

| Male Elbow (TightFLARE)<br>(Female Flare x MNPT) |                 |           |         |      |      |      |
|--|-----------------|-----------|---------|------|------|------|
| PFA Part No.                                     | TightFLARE Size | MNPT Size | Orifice | A    | B    | C    |
| ME4T-4N-3  | 1/4             | 1/4       | .15     | 1.66 | 1.47 | 1.06 |
| ME6T-6N-3  | 3/8             | 3/8       | .25     | 1.76 | 1.53 | 1.06 |
| ME8T-8N-3  | 1/2             | 1/2       | .38     | 1.85 | 1.63 | 1.18 |
| ME12T-12N-3                                      | 3/4             | 3/4       | .63     | 1.76 | 1.53 | 1.36 |
| ME16T-16N-3                                      | 1               | 1         | .88     | 1.76 | 1.49 | 1.18 |

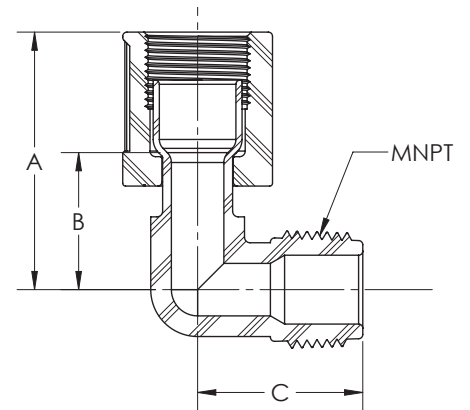

| Male Elbow JIS<br>(Male Flare x Metric Pipe) |           |          |         |      |      |      |
|--|-----------|----------|---------|------|------|------|
| PFA Part No.                                 | Tube O.D. | JIS Size | Orifice | A    | B    | C    |
| ME4-4JN-3                                    | 1/4       | 1/4      | .15     | 1.66 | 1.47 | 1.06 |
| ME4-6JN-3                                    | 1/4       | 3/8      | .15     | 1.66 | 1.47 | 1.06 |
| ME6-4JN-3                                    | 3/8       | 1/4      | .25     | 1.76 | 1.53 | 1.06 |
| ME6-6JN-3                                    | 3/8       | 3/8      | .25     | 1.76 | 1.53 | 1.06 |
| ME6-8JN-3                                    | 3/8       | 1/2      | .25     | 1.76 | 1.53 | 1.18 |
| ME8-4JN-3                                    | 1/2       | 1/4      | .25     | 1.86 | 1.64 | 1.06 |
| ME8-6JN-3                                    | 1/2       | 3/8      | .38     | 1.86 | 1.64 | 1.06 |
| ME8-8JN-3                                    | 1/2       | 1/2      | .38     | 1.86 | 1.64 | 1.18 |
| ME8-12JN-3                                   | 1/2       | 3/4      | .38     | 1.86 | 1.64 | 1.36 |
| ME12-8JN-3                                   | 3/4       | 1/2      | .53     | 2.21 | 1.98 | 1.36 |
| ME12-12JN-3                                  | 3/4       | 3/4      | .63     | 2.21 | 1.98 | 1.37 |
| ME12-16JN-3                                  | 3/4       | 1        | .63     | 2.21 | 1.98 | 1.80 |
| ME16-12JN-3                                  | 1         | 3/4      | .66     | 2.70 | 2.43 | 1.64 |
| ME16-16JN-3                                  | 1         | 1        | .87     | 2.70 | 2.43 | 1.80 |

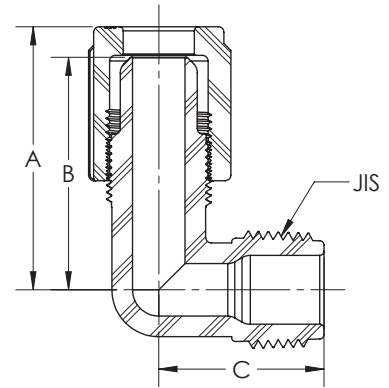

| Female Elbow<br>(Male Flare x FNPT) |           |           |         |      |      |      |
|-------------------------------------|-----------|-----------|---------|------|------|------|
| PFA Part No.                        | Tube O.D. | FNPT Size | Orifice | A    | B    | C    |
| FE4-2N-3                            | 1/4       | 1/8       | .15     | 1.80 | 1.61 | .81  |
| FE4-4N-3                            | 1/4       | 1/4       | .15     | 1.80 | 1.61 | .94  |
| FE4-6N-3                            | 1/4       | 3/8       | .15     | 1.80 | 1.61 | 1.00 |
| FE4-8N-3                            | 1/4       | 1/2       | .15     | 1.80 | 1.61 | 1.25 |
| FE6-4N-3                            | 3/8       | 1/4       | .25     | 1.91 | 1.68 | .94  |
| FE6-6N-3                            | 3/8       | 3/8       | .25     | 1.91 | 1.68 | 1.00 |
| FE6-8N-3                            | 3/8       | 1/2       | .25     | 1.91 | 1.68 | 1.25 |
| FE8-4N-3                            | 1/2       | 1/4       | .36     | 2.03 | 1.81 | .96  |
| FE8-6N-3                            | 1/2       | 3/8       | .38     | 2.03 | 1.81 | 1.00 |
| FE8-8N-3                            | 1/2       | 1/2       | .38     | 2.03 | 1.81 | 1.27 |
| FE8-12N-3                           | 1/2       | 3/4       | .38     | 2.03 | 1.81 | 1.53 |
| FE12-8N-3                           | 3/4       | 1/2       | .54     | 2.22 | 1.99 | 1.44 |
| FE12-12N-3                          | 3/4       | 3/4       | .63     | 2.22 | 1.99 | 1.53 |
| FE16-16N-3                          | 1         | 1         | .88     | 2.67 | 2.40 | 1.60 |

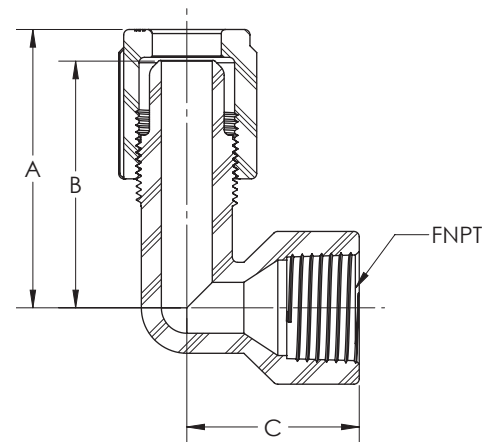

| Union Elbow<br>(Male Flare x Male Flare) |       |         |      |      |
|--|-------|---------|------|------|
| PFA Part No.                             | Tube  | Orifice | A    | B    |
| UE44N-3                                  | 1/4   | .15     | 1.66 | 1.47 |
| UE66N-3                                  | 3/8   | .25     | 1.76 | 1.53 |
| UE88N-3                                  | 1/2   | .38     | 1.87 | 1.65 |
| UE1212N-3                                | 3/4   | .63     | 2.22 | 1.99 |
| UE1616N-3                                | 1     | .87     | 2.70 | 2.43 |
| UE2020N-3                                | 1-1/4 | 1.10    | 2.96 | 2.65 |

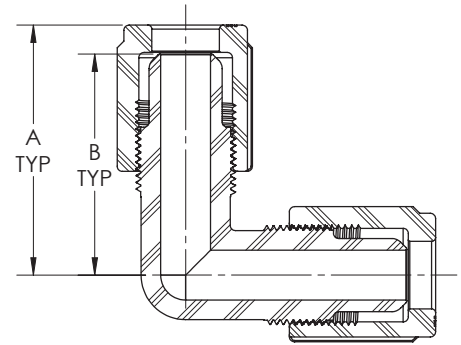

| Union Elbow Reducer<br>(Male Flare x Male Flare) |           |           |         |      |      |      |      |
|--|-----------|-----------|---------|------|------|------|------|
| PFA Part No.                                     | Tube O.D. | Tube O.D. | Orifice | A    | B    | C    | D    |
| UE64N-3  | 3/8       | 1/4       | .15     | 1.76 | 1.53 | 1.47 | 1.66 |
| UE84N-3  | 1/2       | 1/4       | .15     | 1.87 | 1.65 | 1.47 | 1.66 |
| UE86N-3  | 1/2       | 3/8       | .25     | 1.87 | 1.65 | 1.53 | 1.76 |
| UE124N-3   | 3/4       | 1/4       | .15     | 2.22 | 1.99 | 1.47 | 1.66 |
| UE126N-3   | 3/4       | 3/8       | .25     | 2.22 | 1.99 | 1.53 | 1.76 |
| UE128N-3   | 3/4       | 1/2       | .38     | 2.22 | 1.99 | 1.65 | 1.87 |
| UE168N-3   | 1         | 1/2       | .38     | 2.70 | 2.43 | 1.81 | 2.03 |
| UE1612N-3  | 1         | 3/4       | .63     | 2.70 | 2.43 | 1.99 | 2.22 |

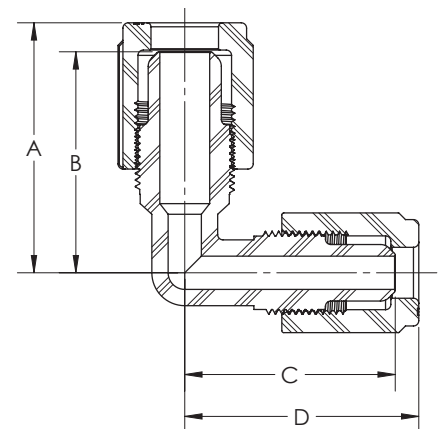

**Union Elbow Panel Mount**  
(Male Flare x Male Flare)

| PFA Part No. | Tube O.D. | Orifice | A    | B    | C   | D    | E    | Min Panel Hole Dia |
|--------------|-----------|---------|------|------|-----|------|------|--------------------|
| EPMX44N-3    | 1/4       | .15     | 1.65 | 2.38 | .52 | 2.19 | 1.45 | 1/2                |
| EPMX66N-3    | 3/8       | .25     | 1.81 | 2.53 | .52 | 2.31 | 1.58 | 5/8                |
| EPMX88N-3    | 1/2       | .38     | 1.88 | 2.58 | .60 | 2.36 | 1.66 | 3/4                |
| EPMX1212N-3  | 3/4       | .63     | 2.22 | 2.93 | .81 | 2.69 | 1.98 | 1                  |

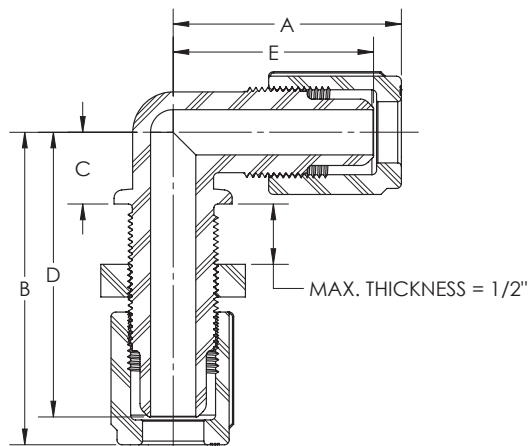

**Union Elbow (TightFLARE)**  
(Male Flare x Female Flare)

| PFA Part No. | Tube O.D. | TightFLARE | Orifice | A    | B    | C    | D    |
|--------------|-----------|------------|---------|------|------|------|------|
| UE44TN-3     | 1/4       | 1/4        | .15     | 1.65 | 1.46 | .87  | 1.64 |
| UE46TN-3     | 1/4       | 3/8        | .15     | 1.65 | 1.46 | .96  | 1.73 |
| UE48TN-3     | 1/4       | 1/2        | .15     | 1.65 | 1.46 | 1.07 | 1.84 |
| UE64TN-3     | 3/8       | 1/4        | .15     | 1.76 | 1.53 | 1.41 | 1.64 |
| UE66TN-3     | 3/8       | 3/8        | .25     | 1.76 | 1.53 | 1.41 | 1.73 |
| UE68TN-3     | 3/8       | 1/2        | .25     | 1.76 | 1.53 | 1.41 | 1.84 |
| UE612TN-3    | 3/8       | 3/4        | .25     | 1.76 | 1.53 | 1.41 | 2.13 |
| UE84TN-3     | 1/2       | 1/4        | .15     | 1.87 | 1.65 | 1.42 | 1.64 |
| UE86TN-3     | 1/2       | 3/8        | .25     | 1.87 | 1.65 | 1.42 | 1.73 |
| UE88TN-3     | 1/2       | 1/2        | .38     | 1.87 | 1.65 | 1.42 | 1.84 |
| UE812TN-3    | 1/2       | 3/4        | .38     | 1.87 | 1.65 | 1.42 | 2.13 |
| UE816TN-3    | 1/2       | 1          | .38     | 2.03 | 1.81 | 1.42 | 2.74 |
| UE126TN-3    | 3/4       | 3/8        | .25     | 2.22 | 1.99 | 1.50 | 1.73 |
| UE128TN-3    | 3/4       | 1/2        | .38     | 2.22 | 1.99 | 1.50 | 1.84 |
| UE1212TN-3   | 3/4       | 3/4        | .63     | 2.22 | 1.99 | 1.50 | 2.13 |
| UE1216TN-3   | 3/4       | 1          | .63     | 2.22 | 1.99 | 1.50 | 2.74 |
| UE1612TN-3   | 1         | 3/4        | .63     | 2.70 | 2.43 | 1.86 | 2.13 |
| UE1616TN-3   | 1         | 1          | .88     | 2.70 | 2.43 | 1.86 | 2.74 |
| UE2020TN-3   | 1-1/4     | 1-1/4      | 1.10    | 2.96 | 2.65 | 2.79 | 3.10 |

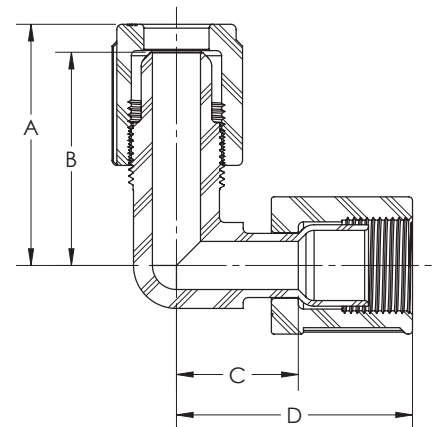

**Union Elbow (TightFLARE)**  
(Female Flare x Female Flare)

| PFA Part No. | TightFLARE | Orifice | A    | B    |
|--------------|------------|---------|------|------|
| UE4TN-3      | 1/4        | .15     | 1.64 | .87  |
| UE6TN-3      | 3/8        | .25     | 1.73 | .88  |
| UE8TN-3      | 1/2        | .38     | 1.84 | .94  |
| UE12TN-3     | 3/4        | .63     | 2.13 | 1.08 |
| UE16TN-3     | 1          | .88     | 2.74 | 1.40 |
| UE20TN-3     | 1-1/4      | 1.10    | 3.10 | 1.80 |

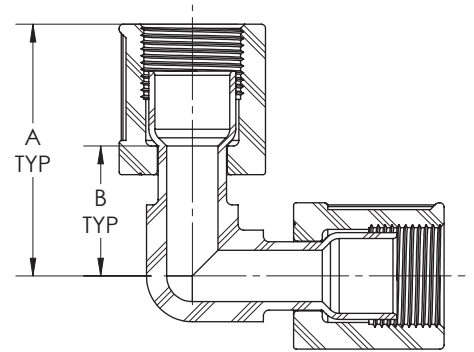

**Union Elbow Reducer (TightFLARE)**  
(Female Flare x Female Flare)

| PFA Part No. | TightFLARE | TightFLARE | Orifice | A    | B    | C    | D    |
|--------------|------------|------------|---------|------|------|------|------|
| UE6T4TN-3    | 3/8        | 1/4        | .15     | 1.73 | .88  | .87  | 1.64 |
| UE8T4TN-3    | 1/2        | 1/4        | .15     | 1.84 | .90  | .87  | 1.64 |
| UE8T6TN-3    | 1/2        | 3/8        | .25     | 1.84 | .90  | .88  | 1.73 |
| UE12T8TN-3   | 3/4        | 1/2        | .38     | 2.13 | 1.08 | .94  | 1.84 |
| UE16T12TN-3  | 1          | 3/4        | .63     | 2.74 | 1.40 | 1.08 | 2.13 |

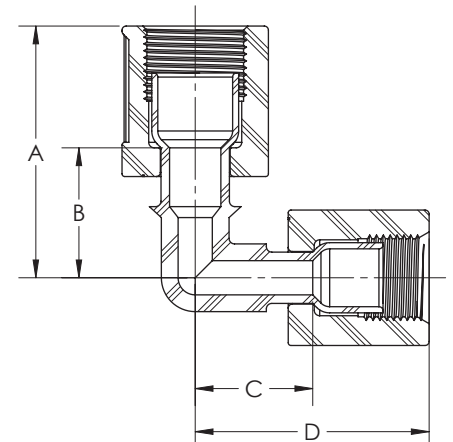

## Flow Coefficient (Cv) Data Comparison

### Fit-Line's 1/4" Sweep Elbow

- 133% more efficient than a standard 1/4" 90° Elbow

### Fit-Line's 3/8" Sweep Elbow

- 67% more efficient than a standard 3/8" 90° Elbow

### Fit-Line's 1/2" Sweep Elbow

- 90% more efficient than a standard 1/2" 90° Elbow
- 38% more efficient than competitor's 1/2" Sweep Elbow

### Fit-Line's 3/4" Sweep Elbow

- 116% more efficient than a standard 3/4" 90° Elbow
- 62% more efficient than competitor's 3/4" Sweep Elbow

### Fit-Line's 1" Sweep Elbow

- 130% more efficient than a standard 1" 90° Elbow
- 69% more efficient than competitor's 1" Sweep Elbow

| Union Elbow Sweep Patented<br>(Male Flare x Male Flare) |           |         |      |      |
|---|-----------|---------|------|------|
| PFA Part No.  | Tube O.D. | Orifice | A    | B    |
| UES44N-3  | 1/4       | .15     | 1.62 | 1.43 |
| UES66N-3  | 3/8       | .25     | 1.83 | 1.60 |
| UES88N-3  | 1/2       | .38     | 2.05 | 1.83 |
| UES1212N-3  | 3/4       | .63     | 2.33 | 2.10 |
| UES1616N-3  | 1         | .88     | 2.78 | 2.51 |

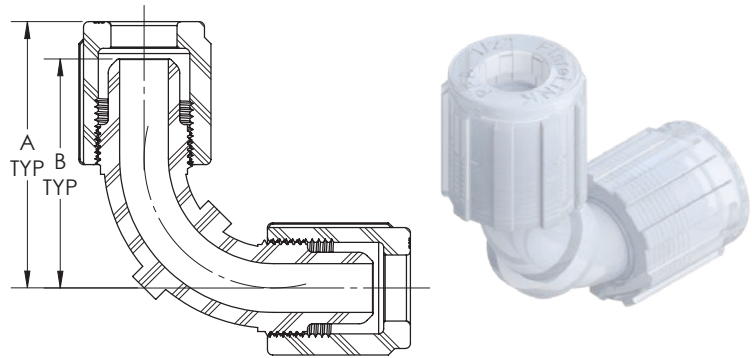

| Union Elbow Sweep (TightFLARE) Patented<br>(Male Flare x Female Flare) |                        |         |      |      |      |      |
|--|------------------------|---------|------|------|------|------|
| PFA Part No.   | Tube O.D. / TightFLARE | Orifice | A    | B    | C    | D    |
| UES44TN-3  | 1/4                    | .15     | 1.78 | 1.01 | 1.43 | 1.62 |
| UES66TN-3  | 3/8                    | .25     | 1.97 | 1.12 | 1.60 | 1.83 |
| UES88TN-3  | 1/2                    | .38     | 2.16 | 1.25 | 1.76 | 1.98 |
| UES1212TN-3  | 3/4                    | .63     | 2.56 | 1.51 | 2.10 | 2.33 |
| UES1616TN-3  | 1                      | .88     | 3.22 | 1.88 | 2.51 | 2.78 |

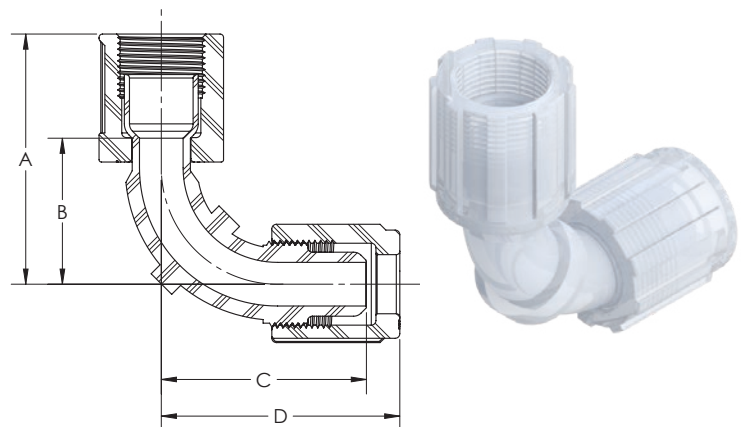

| Union Elbow Sweep (TightFLARE) Patented<br>(Female Flare x Female Flare) |            |         |      |      |
|--|------------|---------|------|------|
| PFA Part No.   | TightFLARE | Orifice | A    | B    |
| UES4TN-3   | 1/4        | .15     | 1.78 | 1.01 |
| UES6TN-3   | 3/8        | .25     | 1.97 | 1.12 |
| UES8TN-3   | 1/2        | .38     | 2.15 | 1.25 |
| UES12TN-3  | 3/4        | .63     | 2.56 | 1.51 |
| UES16TN-3  | 1          | .88     | 3.22 | 1.88 |

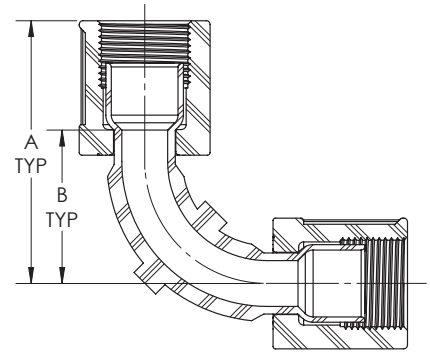

| Male Elbow Sweep Patented<br>(Male Flare x MNPT) |                  |         |      |      |      |
|--|------------------|---------|------|------|------|
| PFA Part No.                                     | Tube O.D. / MNPT | Orifice | A    | B    | C    |
| MES4-4N-3  | 1/4              | .15     | 1.62 | 1.43 | 1.20 |
| MES6-6N-3  | 3/8              | .25     | 1.83 | 1.60 | 1.32 |
| MES8-8N-3  | 1/2              | .38     | 2.05 | 1.83 | 1.55 |
| MES12-12N-3                                      | 3/4              | .63     | 2.33 | 2.10 | 1.76 |
| MES16-16N-3                                      | 1                | .88     | 2.78 | 2.51 | 2.26 |

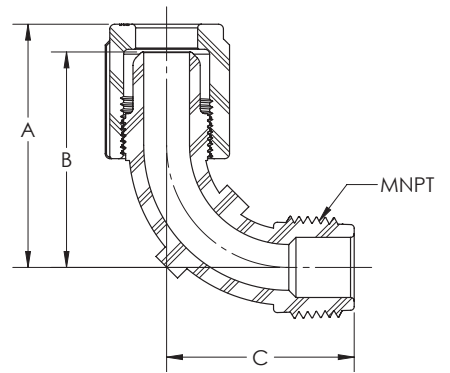

| Male Elbow Sweep (TightFLARE) Patented<br>(Female Flare x MNPT) |                   |         |      |      |      |
|---|-------------------|---------|------|------|------|
| PFA Part No.  | TightFLARE / MNPT | Orifice | A    | B    | C    |
| MES4T-4N-3  | 1/4               | .15     | 1.78 | 1.01 | 1.20 |
| MES6T-6N-3  | 3/8               | .25     | 1.97 | 1.12 | 1.32 |
| MES8T-8N-3  | 1/2               | .38     | 2.15 | 1.25 | 1.55 |
| MES12T-12N-3  | 3/4               | .63     | 2.56 | 1.51 | 1.76 |
| MES16T-16N-3  | 1                 | .88     | 3.22 | 1.88 | 2.26 |

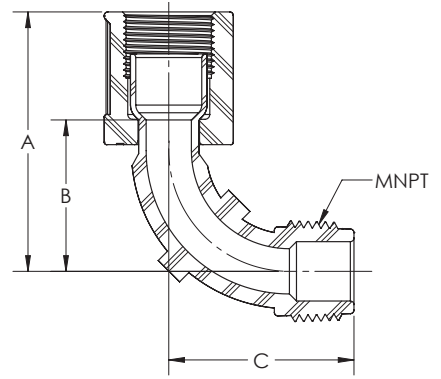

| Union Tee<br>(Male Flare x Male Flare x Male Flare) |           |         |      |      |      |
|---|-----------|---------|------|------|------|
| PFA Part No.  | Tube O.D. | Orifice | A    | B    | C    |
| UT4N-3  | 1/4       | .15     | 3.32 | 1.66 | 1.47 |
| UT6N-3  | 3/8       | .25     | 3.52 | 1.76 | 1.53 |
| UT8N-3  | 1/2       | .38     | 3.74 | 1.87 | 1.65 |
| UT12N-3   | 3/4       | .63     | 4.44 | 2.22 | 1.99 |
| UT16N-3   | 1         | .88     | 5.40 | 2.70 | 2.43 |
| UT20N-3   | 1-1/4     | 1.10    | 5.92 | 2.96 | 2.65 |

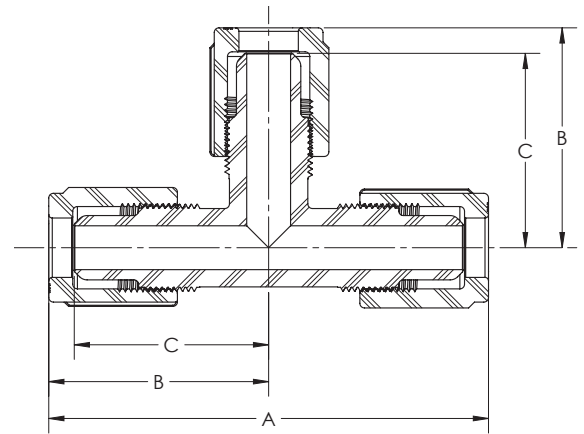

**Union Tee Reducer**  
(Male Flare x Male Flare x Male Flare)

| PFA Part No.  | X     | Y   | Z     | Orifice | A    | B1   | B2   | C    | D    |
|---------------|-------|-----|-------|---------|------|------|------|------|------|
| UT4-6-4N-3    | 1/4   | 3/8 | 1/4   | .15     | 3.32 | 1.47 | 1.47 | 1.53 | 1.76 |
| UT4-8-4N-3    | 1/4   | 1/2 | 1/4   | .15     | 3.32 | 1.47 | 1.47 | 1.65 | 1.87 |
| UT6-4-4N-3    | 3/8   | 1/4 | 1/4   | .15     | 3.42 | 1.53 | 1.47 | 1.47 | 1.66 |
| UT6-4-6N-3    | 3/8   | 1/4 | 3/8   | .15     | 3.52 | 1.53 | 1.53 | 1.47 | 1.66 |
| UT6-6-4N-3    | 3/8   | 3/8 | 1/4   | .15     | 3.42 | 1.53 | 1.47 | 1.53 | 1.76 |
| UT6-8-6N-3    | 3/8   | 1/2 | 3/8   | .25     | 3.52 | 1.53 | 1.53 | 1.65 | 1.87 |
| UT6-12-6N-3   | 3/8   | 3/4 | 3/8   | .25     | 3.52 | 1.53 | 1.53 | 1.98 | 2.23 |
| UT8-4-4N-3    | 1/2   | 1/4 | 1/4   | .15     | 3.53 | 1.65 | 1.47 | 1.47 | 1.66 |
| UT8-4-6N-3    | 1/2   | 1/4 | 3/8   | .15     | 3.63 | 1.65 | 1.53 | 1.47 | 1.66 |
| UT8-4-8N-3    | 1/2   | 1/4 | 1/2   | .15     | 3.74 | 1.65 | 1.65 | 1.47 | 1.66 |
| UT8-6-6N-3    | 1/2   | 3/8 | 3/8   | .25     | 3.63 | 1.65 | 1.53 | 1.53 | 1.76 |
| UT8-6-8N-3    | 1/2   | 3/8 | 1/2   | .25     | 3.74 | 1.65 | 1.65 | 1.53 | 1.76 |
| UT8-8-4N-3    | 1/2   | 1/2 | 1/4   | .15     | 3.53 | 1.65 | 1.47 | 1.65 | 1.87 |
| UT8-8-6N-3    | 1/2   | 1/2 | 3/8   | .38     | 3.63 | 1.65 | 1.53 | 1.65 | 1.87 |
| UT8-12-8N-3   | 1/2   | 3/4 | 1/2   | .38     | 3.72 | 1.66 | 1.65 | 1.99 | 2.22 |
| UT12-4-12N-3  | 3/4   | 1/4 | 3/4   | .15     | 4.44 | 1.99 | 1.99 | 1.47 | 1.66 |
| UT12-6-12N-3  | 3/4   | 3/8 | 3/4   | .25     | 4.44 | 1.99 | 1.99 | 1.53 | 1.76 |
| UT12-8-8N-3   | 3/4   | 1/2 | 1/2   | .38     | 4.09 | 1.99 | 1.65 | 1.65 | 1.87 |
| UT12-8-12N-3  | 3/4   | 1/2 | 3/4   | .38     | 4.44 | 1.99 | 1.99 | 1.65 | 1.87 |
| UT12-12-4N-3  | 3/4   | 3/4 | 1/4   | .15     | 3.90 | 1.99 | 1.47 | 1.99 | 2.24 |
| UT12-12-6N-3  | 3/4   | 3/4 | 3/8   | .25     | 3.98 | 1.99 | 1.53 | 1.99 | 2.22 |
| UT12-12-8N-3  | 3/4   | 3/4 | 1/2   | .38     | 4.09 | 1.99 | 1.65 | 1.99 | 2.22 |
| UT12-16-12N-3 | 3/4   | 1   | 3/4   | .63     | 4.44 | 1.99 | 1.99 | 2.43 | 2.70 |
| UT16-4-16N-3  | 1     | 1/4 | 1     | .15     | 5.40 | 2.43 | 2.43 | 1.83 | 2.02 |
| UT16-6-16N-3  | 1     | 3/8 | 1     | .25     | 5.40 | 2.43 | 2.43 | 1.90 | 2.13 |
| UT16-8-16N-3  | 1     | 1/2 | 1     | .38     | 5.40 | 2.43 | 2.43 | 2.04 | 2.26 |
| UT16-12-12N-3 | 1     | 3/4 | 3/4   | .63     | 5.40 | 2.43 | 1.99 | 1.99 | 2.22 |
| UT16-12-16N-3 | 1     | 3/4 | 1     | .63     | 4.92 | 2.43 | 2.43 | 1.99 | 2.22 |
| UT16-16-4N-3  | 1     | 1   | 1/4   | .15     | 4.69 | 2.41 | 1.83 | 2.41 | 2.69 |
| UT16-16-6N-3  | 1     | 1   | 3/8   | .25     | 4.77 | 2.41 | 1.90 | 2.41 | 2.69 |
| UT16-16-8N-3  | 1     | 1   | 1/2   | .38     | 4.92 | 2.43 | 2.00 | 2.43 | 2.70 |
| UT16-16-12N-3 | 1     | 1   | 3/4   | .63     | 4.92 | 2.43 | 1.99 | 2.43 | 2.70 |
| UT20-16-20N-3 | 1-1/4 | 1   | 1-1/4 | .88     | 5.90 | 2.65 | 2.65 | 2.41 | 2.69 |

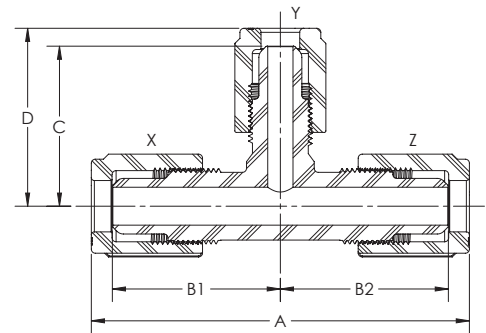

**Union Tee (TightFLARE) Branch**  
(Male Flare x Female Flare x Male Flare)

| PFA Part No.   | X     | Y     | Z     | Orifice | A    | B1   | B2   | C    | D    |
|----------------|-------|-------|-------|---------|------|------|------|------|------|
| UT4-4T-4N-3    | 1/4   | 1/4   | 1/4   | .15     | 3.32 | 1.47 | 1.47 | .87  | 1.64 |
| UT4-6T-4N-3    | 1/4   | 3/8   | 1/4   | .15     | 3.32 | 1.47 | 1.47 | .88  | 1.73 |
| UT6-4T-6N-3    | 3/8   | 1/4   | 3/8   | .15     | 3.52 | 1.53 | 1.53 | .87  | 1.64 |
| UT6-6T-4N-3    | 3/8   | 3/8   | 1/4   | .15     | 3.42 | 1.53 | .89  | .88  | 1.73 |
| UT6-6T-6N-3    | 3/8   | 3/8   | 3/8   | .25     | 3.52 | 1.53 | 1.53 | .88  | 1.73 |
| UT6-8T-6N-3    | 3/8   | 1/2   | 3/8   | .25     | 3.52 | 1.53 | 1.53 | .94  | 1.84 |
| UT8-4T-8N-3    | 1/2   | 1/4   | 1/2   | .15     | 3.74 | 1.65 | 1.65 | .87  | 1.64 |
| UT8-6T-8N-3    | 1/2   | 3/8   | 1/2   | .25     | 3.74 | 1.65 | 1.65 | .88  | 1.73 |
| UT8-8T-4N-3    | 1/2   | 1/2   | 1/4   | .15     | 3.53 | 1.65 | 1.47 | .94  | 1.84 |
| UT8-8T-6N-3    | 1/2   | 1/2   | 3/8   | .25     | 3.63 | 1.65 | 1.53 | .94  | 1.84 |
| UT8-8T-8N-3    | 1/2   | 1/2   | 1/2   | .38     | 3.74 | 1.65 | 1.65 | .94  | 1.84 |
| UT8-12T-8N-3   | 1/2   | 3/4   | 1/2   | .38     | 3.74 | 1.65 | 1.65 | 1.08 | 2.13 |
| UT12-4T-12N-3  | 3/4   | 1/4   | 3/4   | .15     | 4.44 | 1.99 | 1.99 | .87  | 1.64 |
| UT12-6T-12N-3  | 3/4   | 3/8   | 3/4   | .25     | 4.44 | 1.99 | 1.99 | .88  | 1.73 |
| UT12-8T-8N-3   | 3/4   | 1/2   | 1/2   | .38     | 4.09 | 1.99 | 1.65 | .94  | 1.84 |
| UT12-8T-12N-3  | 3/4   | 1/2   | 3/4   | .38     | 4.44 | 1.99 | 1.99 | 1.07 | 1.97 |
| UT12-12T-6N-3  | 3/4   | 3/4   | 3/8   | .25     | 3.98 | 1.99 | 1.53 | 1.08 | 2.13 |
| UT12-12T-8N-3  | 3/4   | 3/4   | 1/2   | .38     | 4.09 | 1.99 | 1.65 | 1.08 | 2.13 |
| UT12-12T-12N-3 | 3/4   | 3/4   | 3/4   | .63     | 4.44 | 1.99 | 1.99 | 1.08 | 2.13 |
| UT12-16T-12N-3 | 3/4   | 1     | 3/4   | .63     | 4.44 | 1.99 | 1.99 | 1.40 | 2.74 |
| UT16-8T-16N-3  | 1     | 1/2   | 1     | .38     | 5.40 | 2.43 | 2.43 | 1.19 | 2.09 |
| UT16-12T-12N-3 | 1     | 3/4   | 3/4   | .63     | 4.92 | 2.43 | 1.99 | 1.08 | 2.13 |
| UT16-12T-16N-3 | 1     | 3/4   | 1     | .63     | 5.40 | 2.43 | 2.43 | 1.18 | 2.23 |
| UT16-16T-12N-3 | 1     | 1     | 3/4   | .63     | 4.95 | 2.43 | 1.99 | 1.40 | 2.74 |
| UT16-16T-16N-3 | 1     | 1     | 1     | .88     | 5.40 | 2.43 | 2.43 | 1.40 | 2.74 |
| UT20-20T-20N-3 | 1-1/4 | 1-1/4 | 1-1/4 | 1.10    | 5.92 | 2.65 | 2.65 | 1.80 | 3.10 |

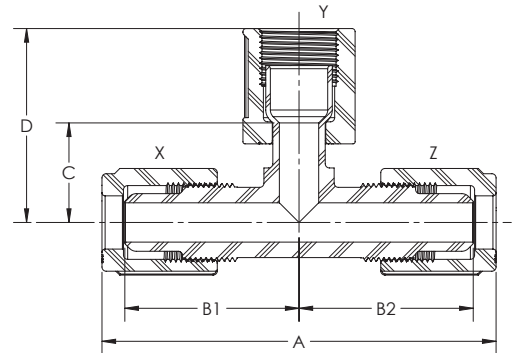

**Union Tee (TightFLARE) Run**  
(Male Flare x Male Flare x Female Flare)

| PFA Part No.   | X     | Y     | Z     | Orifice | A    | B1   | B2   | C    | D    |
|----------------|-------|-------|-------|---------|------|------|------|------|------|
| UT4-4-4TN-3    | 1/4   | 1/4   | 1/4   | .15     | 3.30 | 1.47 | .87  | 1.47 | 1.66 |
| UT4-8-8TN-3    | 1/4   | 1/2   | 1/2   | .15     | 3.50 | 1.47 | .94  | 1.65 | 1.87 |
| UT6-4-6TN-3    | 3/8   | 1/4   | 3/8   | .15     | 3.49 | 1.53 | .88  | 1.47 | 1.66 |
| UT6-6-6TN-3    | 3/8   | 3/8   | 3/8   | .25     | 3.49 | 1.53 | .88  | 1.53 | 1.76 |
| UT6-6-8TN-3    | 3/8   | 3/8   | 1/2   | .25     | 3.60 | 1.53 | .94  | 1.53 | 1.76 |
| UT6-8-8TN-3    | 3/8   | 1/2   | 1/2   | .25     | 3.60 | 1.53 | .94  | 1.65 | 1.87 |
| UT6-12-12TN-3  | 3/8   | 3/4   | 3/4   | .25     | 3.89 | 1.53 | 1.08 | 1.99 | 2.22 |
| UT6-16-16TN-3  | 3/8   | 1     | 1     | .25     | 4.82 | 1.90 | 1.40 | 2.41 | 2.69 |
| UT8-4-8TN-3    | 1/2   | 1/4   | 1/2   | .15     | 3.71 | 1.65 | .94  | 1.47 | 1.66 |
| UT8-6-6TN-3    | 1/2   | 3/8   | 3/8   | .25     | 3.60 | 1.65 | .88  | 1.53 | 1.76 |
| UT8-6-8TN-3    | 1/2   | 3/8   | 1/2   | .25     | 3.71 | 1.65 | .94  | 1.53 | 1.76 |
| UT8-8-6TN-3    | 1/2   | 1/2   | 3/8   | .25     | 3.60 | 1.65 | .88  | 1.65 | 1.87 |
| UT8-8-8TN-3    | 1/2   | 1/2   | 1/2   | .38     | 3.71 | 1.65 | .94  | 1.65 | 1.87 |
| UT8-8-12TN-3   | 1/2   | 1/2   | 3/4   | .38     | 4.00 | 1.65 | 1.08 | 1.65 | 1.87 |
| UT12-4-12TN-3  | 3/4   | 1/4   | 3/4   | .15     | 4.35 | 1.99 | 1.08 | 1.47 | 1.66 |
| UT12-6-12TN-3  | 3/4   | 3/8   | 3/4   | .25     | 4.35 | 1.99 | 1.08 | 1.53 | 1.76 |
| UT12-8-12TN-3  | 3/4   | 1/2   | 3/4   | .38     | 4.35 | 1.99 | 1.08 | 1.65 | 1.87 |
| UT12-12-8TN-3  | 3/4   | 3/4   | 1/2   | .38     | 4.06 | 1.99 | .94  | 1.99 | 2.22 |
| UT12-12-12TN-3 | 3/4   | 3/4   | 3/4   | .63     | 4.35 | 1.99 | 1.08 | 1.99 | 2.22 |
| UT16-4-16TN-3  | 1     | 1/4   | 1     | .15     | 5.44 | 2.43 | 1.40 | 1.83 | 2.02 |
| UT16-6-16TN-3  | 1     | 3/8   | 1     | .25     | 5.44 | 2.43 | 1.40 | 1.90 | 2.13 |
| UT16-8-16TN-3  | 1     | 1/2   | 1     | .38     | 5.44 | 2.43 | 1.40 | 2.04 | 2.26 |
| UT16-12-16TN-3 | 1     | 3/4   | 1     | .63     | 5.44 | 2.43 | 1.40 | 1.99 | 2.22 |
| UT16-16-12TN-3 | 1     | 1     | 3/4   | .63     | 4.94 | 2.43 | 1.40 | 2.43 | 2.70 |
| UT16-16-16TN-3 | 1     | 1     | 1     | .88     | 5.44 | 2.43 | 1.40 | 2.43 | 2.70 |
| UT20-20-20TN-3 | 1-1/4 | 1-1/4 | 1-1/4 | 1.10    | 6.06 | 2.65 | 1.80 | 2.65 | 2.96 |

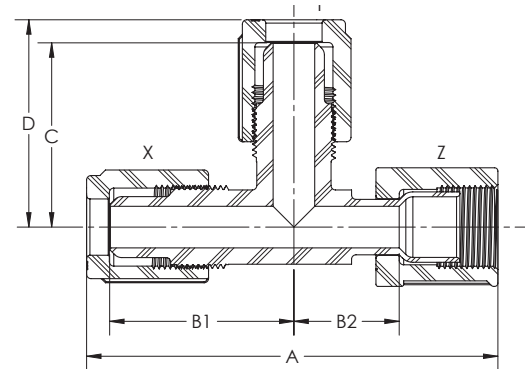

**Union Tee (TightFLARE) Branch, Run**  
(Male Flare x Female Flare x Female Flare)

| PFA Part No.    | X     | Y     | Z     | Orifice | A    | B1   | B2   | C    | D    |
|-----------------|-------|-------|-------|---------|------|------|------|------|------|
| UT4-4T-4TN-3    | 1/4   | 1/4   | 1/4   | .15     | 3.30 | 1.47 | .77  | .87  | 1.64 |
| UT6-4T-6TN-3    | 3/8   | 1/4   | 3/8   | .15     | 3.49 | 1.53 | .88  | .87  | 1.64 |
| UT6-6T-6TN-3    | 3/8   | 3/8   | 3/8   | .25     | 3.49 | 1.53 | .88  | .88  | 1.73 |
| UT6-8T-8TN-3    | 3/8   | 1/2   | 1/2   | .25     | 3.60 | 1.53 | .94  | .94  | 1.84 |
| UT6-12T-12TN-3  | 3/8   | 3/4   | 3/4   | .25     | 3.89 | 1.53 | 1.08 | 1.08 | 2.13 |
| UT8-6T-6TN-3    | 1/2   | 3/8   | 3/8   | .25     | 3.60 | 1.65 | .88  | .88  | 1.73 |
| UT8-6T-8TN-3    | 1/2   | 3/8   | 1/2   | .25     | 3.71 | 1.65 | .94  | .88  | 1.73 |
| UT8-8T-8TN-3    | 1/2   | 1/2   | 1/2   | .38     | 3.71 | 1.65 | .94  | .94  | 1.84 |
| UT8-8T-12TN-3   | 1/2   | 1/2   | 3/4   | .38     | 4.00 | 1.65 | 1.08 | .94  | 1.84 |
| UT8-12T-12TN-3  | 1/2   | 3/4   | 3/4   | .38     | 4.00 | 1.65 | 1.08 | 1.08 | 2.13 |
| UT12-8T-8TN-3   | 3/4   | 1/2   | 1/2   | .38     | 4.06 | 1.99 | .94  | .94  | 1.84 |
| UT12-8T-12TN-3  | 3/4   | 1/2   | 3/4   | .38     | 4.35 | 1.99 | 1.08 | .94  | 1.84 |
| UT12-12T-8TN-3  | 3/4   | 3/4   | 1/2   | .38     | 4.06 | 1.99 | .94  | 1.08 | 2.13 |
| UT12-12T-12TN-3 | 3/4   | 3/4   | 3/4   | .63     | 4.35 | 1.99 | 1.08 | 1.08 | 2.13 |
| UT16-8T-16TN-3  | 1     | 1/2   | 1     | .38     | 5.44 | 2.43 | 1.40 | 1.19 | 2.09 |
| UT16-12T-12TN-3 | 1     | 3/4   | 3/4   | .63     | 4.83 | 2.43 | 1.08 | 1.08 | 2.13 |
| UT16-12T-16TN-3 | 1     | 3/4   | 1     | .63     | 5.44 | 2.43 | 1.40 | 1.08 | 2.13 |
| UT16-16T-12TN-3 | 1     | 1     | 3/4   | .63     | 4.94 | 2.43 | 1.19 | 1.40 | 2.74 |
| UT16-16T-16TN-3 | 1     | 1     | 1     | .88     | 5.44 | 2.43 | 1.40 | 1.40 | 2.74 |
| UT20-16T-20TN-3 | 1-1/4 | 1     | 1-1/4 | .88     | 6.06 | 2.65 | 1.80 | 1.25 | 2.59 |
| UT20-20T-20TN-3 | 1-1/4 | 1-1/4 | 1-1/4 | 1.10    | 6.06 | 2.65 | 1.80 | 1.80 | 3.10 |

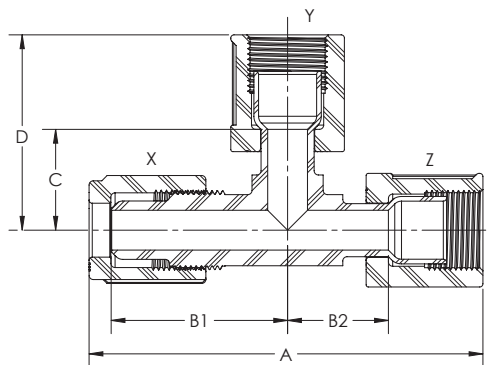

**Union Tee (TightFLARE) Run, Run**  
(Female Flare x Male Flare x Female Flare)

| PFA Part No.    | X     | Y     | Z     | Orifice | A    | B1   | B2   | C    | D    |
|-----------------|-------|-------|-------|---------|------|------|------|------|------|
| UT4T-4-4TN-3    | 1/4   | 1/4   | 1/4   | .15     | 3.28 | .87  | .87  | 1.47 | 1.66 |
| UT4T-6-4TN-3    | 1/4   | 3/8   | 1/4   | .15     | 3.28 | .87  | .87  | 1.53 | 1.76 |
| UT6T-4-6TN-3    | 3/8   | 1/4   | 3/8   | .15     | 3.46 | .88  | .88  | 1.47 | 1.66 |
| UT6T-6-6TN-3    | 3/8   | 3/8   | 3/8   | .25     | 3.46 | .88  | .88  | 1.53 | 1.76 |
| UT6T-8-6TN-3    | 3/8   | 1/2   | 3/8   | .25     | 3.46 | .88  | .88  | 1.65 | 1.87 |
| UT8T-4-8TN-3    | 1/2   | 1/4   | 1/2   | .15     | 3.68 | .94  | .94  | 1.47 | 1.66 |
| UT8T-6-6TN-3    | 1/2   | 3/8   | 3/8   | .25     | 3.57 | .94  | .88  | 1.53 | 1.76 |
| UT8T-8-4TN-3    | 1/2   | 1/2   | 1/4   | .15     | 3.48 | .94  | .87  | 1.65 | 1.87 |
| UT8T-8-6TN-3    | 1/2   | 1/2   | 3/8   | .25     | 3.57 | .94  | .88  | 1.65 | 1.87 |
| UT8T-8-8TN-3    | 1/2   | 1/2   | 1/2   | .38     | 3.68 | .94  | .94  | 1.65 | 1.87 |
| UT8T-12-8TN-3   | 1/2   | 3/4   | 1/2   | .38     | 3.68 | .94  | .94  | 1.99 | 2.22 |
| UT12T-4-12TN-3  | 3/4   | 1/4   | 3/4   | .15     | 4.26 | 1.08 | 1.08 | 1.47 | 1.66 |
| UT12T-6-12TN-3  | 3/4   | 3/8   | 3/4   | .25     | 4.26 | 1.08 | 1.08 | 1.53 | 1.76 |
| UT12T-8-8TN-3   | 3/4   | 1/2   | 1/2   | .38     | 4.26 | 1.08 | 1.08 | 1.65 | 1.87 |
| UT12T-8-12TN-3  | 3/4   | 1/2   | 3/4   | .38     | 4.26 | 1.08 | 1.08 | 1.65 | 1.87 |
| UT12T-12-12TN-3 | 3/4   | 3/4   | 3/4   | .63     | 4.26 | 1.08 | 1.08 | 1.99 | 2.22 |
| UT12T-16-12TN-3 | 3/4   | 1     | 3/4   | .63     | 4.26 | 1.08 | 1.08 | 2.43 | 2.70 |
| UT16T-6-16TN-3  | 1     | 3/8   | 1     | .25     | 5.48 | 1.40 | 1.40 | 1.90 | 2.13 |
| UT16T-8-16TN-3  | 1     | 1/2   | 1     | .38     | 5.48 | 1.40 | 1.40 | 2.04 | 2.26 |
| UT16T-12-16TN-3 | 1     | 3/4   | 1     | .63     | 5.48 | 1.40 | 1.40 | 1.98 | 2.21 |
| UT16T-16-16TN-3 | 1     | 1     | 1     | .88     | 5.48 | 1.40 | 1.40 | 2.43 | 2.70 |
| UT20T-20-20TN-3 | 1-1/4 | 1-1/4 | 1-1/4 | 1.10    | 6.20 | 1.80 | 1.80 | 2.65 | 2.96 |

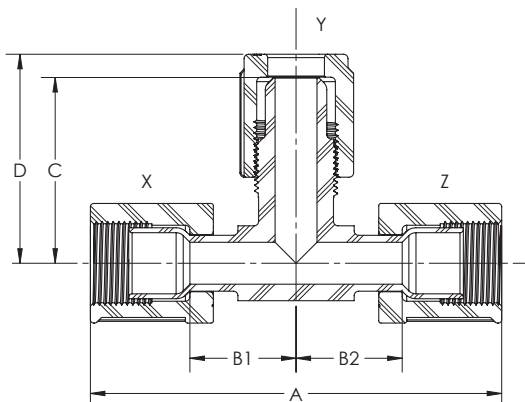

**Union Tee (TightFLARE) All**  
(Female Flare x Female Flare x Female Flare)

| PFA Part No.     | X     | Y     | Z     | Orifice | A    | B1   | B2   | C    | D    |
|------------------|-------|-------|-------|---------|------|------|------|------|------|
| UT4TN-3          | 1/4   | 1/4   | 1/4   | .15     | 3.28 | .87  | .87  | .87  | 1.64 |
| UT4T-6T-4TN-3    | 1/4   | 3/8   | 1/4   | .15     | 3.28 | .87  | .87  | .88  | 1.73 |
| UT6TN-3          | 3/8   | 3/8   | 3/8   | .25     | 3.46 | .88  | .88  | .88  | 1.73 |
| UT6T-8T-4TN-3    | 3/8   | 1/2   | 1/4   | .15     | 3.37 | .88  | .87  | .94  | 1.84 |
| UT8TN-3          | 1/2   | 1/2   | 1/2   | .38     | 3.68 | .94  | .94  | .94  | 1.84 |
| UT8T-6T-6TN-3    | 1/2   | 3/8   | 3/8   | .25     | 3.57 | .94  | .88  | .88  | 1.73 |
| UT8T-8T-4TN-3    | 1/2   | 1/2   | 1/4   | .15     | 3.48 | .94  | .87  | .94  | 1.84 |
| UT8T-12T-8TN-3   | 1/2   | 3/4   | 1/2   | .38     | 3.68 | .94  | .94  | 1.08 | 2.13 |
| UT12TN-3         | 3/4   | 3/4   | 3/4   | .63     | 4.26 | 1.08 | 1.08 | 1.08 | 2.13 |
| UT12T-6T-12TN-3  | 3/4   | 3/8   | 3/4   | .25     | 4.26 | 1.08 | 1.08 | .88  | 1.73 |
| UT12T-8T-12TN-3  | 3/4   | 1/2   | 3/4   | .38     | 4.23 | 1.08 | 1.08 | .94  | 1.84 |
| UT12T-12T-8TN-3  | 3/4   | 3/4   | 1/2   | .38     | 3.97 | 1.08 | .94  | 1.08 | 2.13 |
| UT16T-12T-16TN-3 | 1     | 3/4   | 1     | .63     | 5.48 | 1.40 | 1.40 | 1.08 | 2.13 |
| UT16TN-3         | 1     | 1     | 1     | .88     | 5.48 | 1.40 | 1.40 | 1.40 | 2.74 |
| UT20TN-3         | 1-1/4 | 1-1/4 | 1-1/4 | 1.10    | 6.20 | 1.80 | 1.80 | 1.80 | 3.10 |
| UT20T-16T-20TN-3 | 1-1/4 | 1     | 1-1/4 | .88     | 6.20 | 1.80 | 1.80 | 1.25 | 2.59 |

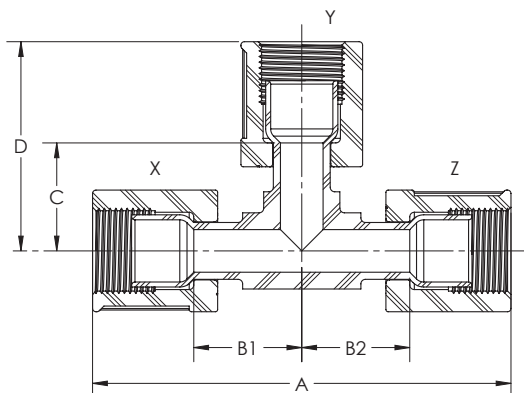

**Male Run Tee**  
(Male Flare x Male Flare x MNPT)

| PFA Part No.  | Tube O.D. | Tube O.D. | MNPT Size | Orifice | A    | B    | C    |
|---------------|-----------|-----------|-----------|---------|------|------|------|
| MRT44-2N-3    | 1/4       | 1/4       | 1/8       | .15     | 2.72 | 1.49 | 1.68 |
| MRT44-4N-3    | 1/4       | 1/4       | 1/4       | .15     | 2.72 | 1.49 | 1.68 |
| MRT44-6N-3    | 1/4       | 1/4       | 3/8       | .15     | 2.72 | 1.49 | 1.68 |
| MRT66-2N-3    | 3/8       | 3/8       | 1/8       | .17     | 2.83 | 1.53 | 1.76 |
| MRT66-4N-3    | 3/8       | 3/8       | 1/4       | .25     | 2.83 | 1.53 | 1.76 |
| MRT66-6N-3    | 3/8       | 3/8       | 3/8       | .25     | 2.83 | 1.53 | 1.76 |
| MRT66-8N-3    | 3/8       | 3/8       | 1/2       | .25     | 2.83 | 1.53 | 1.76 |
| MRT88-6N-3    | 1/2       | 1/2       | 3/8       | .38     | 2.96 | 1.65 | 1.87 |
| MRT88-8N-3    | 1/2       | 1/2       | 1/2       | .38     | 3.04 | 1.65 | 1.87 |
| MRT1212-6N-3  | 3/4       | 3/4       | 3/8       | .38     | 3.45 | 1.99 | 2.22 |
| MRT1212-8N-3  | 3/4       | 3/4       | 1/2       | .49     | 3.56 | 1.99 | 2.22 |
| MRT1212-12N-3 | 3/4       | 3/4       | 3/4       | .63     | 3.59 | 1.99 | 2.22 |
| MRT1616-12N-3 | 1         | 1         | 3/4       | .63     | 4.34 | 2.43 | 2.70 |
| MRT1616-16N-3 | 1         | 1         | 1         | .88     | 4.50 | 2.43 | 2.70 |

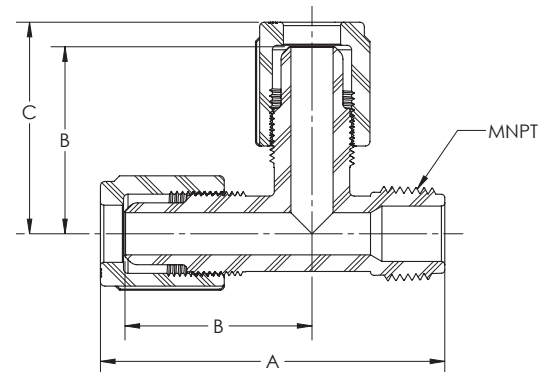

**Male Branch Tee (TightFLARE)**  
(Female Flare x MNPT x Female Flare)

| PFA Part No.    | TightFLARE | MNPT Size | Orifice | A    | B    | C    |
|-----------------|------------|-----------|---------|------|------|------|
| MBT12T12T-8N-3  | 3/4        | 1/2       | .49     | 4.24 | 1.07 | 1.35 |
| MBT16T16T-8N-3  | 1          | 1/2       | .49     | 5.48 | 1.40 | 1.63 |
| MBT16T16T-16N-3 | 1          | 1         | .88     | 5.48 | 1.40 | 1.81 |

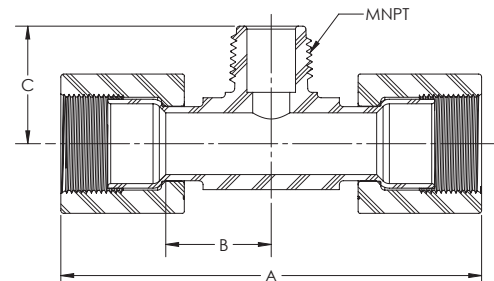

### Male Branch Tee

(Male Flare x MNPT x Male Flare)

| PFA Part No.  | Tube O.D. | Tube O.D. | MNPT Size | Orifice | A    | B1   | B2   | C    |
|---------------|-----------|-----------|-----------|---------|------|------|------|------|
| MBT44-2N-3    | 1/4       | 1/4       | 1/8       | .15     | 3.32 | 1.47 | 1.47 | 1.07 |
| MBT44-4N-3    | 1/4       | 1/4       | 1/4       | .15     | 3.32 | 1.47 | 1.47 | 1.07 |
| MBT44-8N-3    | 1/4       | 1/4       | 1/2       | .15     | 3.32 | 1.47 | 1.47 | 1.17 |
| MBT64-4N-3    | 3/8       | 1/4       | 1/4       | .15     | 3.42 | 1.53 | 1.47 | 1.07 |
| MBT64-6N-3    | 3/8       | 1/4       | 3/8       | .15     | 3.52 | 1.53 | 1.57 | 1.07 |
| MBT66-2N-3    | 3/8       | 3/8       | 1/8       | .25     | 3.52 | 1.53 | 1.53 | 1.07 |
| MBT66-4N-3    | 3/8       | 3/8       | 1/4       | .25     | 3.52 | 1.53 | 1.53 | 1.07 |
| MBT66-6N-3    | 3/8       | 3/8       | 3/8       | .25     | 3.52 | 1.53 | 1.53 | 1.07 |
| MBT66-8N-3    | 3/8       | 3/8       | 1/2       | .25     | 3.52 | 1.53 | 1.53 | 1.17 |
| MBT84-8N-3    | 1/2       | 1/4       | 1/2       | .15     | 3.53 | 1.65 | 1.47 | 1.17 |
| MBT86-6N-3    | 1/2       | 3/8       | 3/8       | .25     | 3.64 | 1.65 | 1.54 | 1.08 |
| MBT86-8N-3    | 1/2       | 3/8       | 1/2       | .25     | 3.64 | 1.65 | 1.54 | 1.17 |
| MBT88-4N-3    | 1/2       | 1/2       | 1/4       | .25     | 3.74 | 1.65 | 1.65 | 1.07 |
| MBT88-6N-3    | 1/2       | 1/2       | 3/8       | .38     | 3.74 | 1.65 | 1.65 | 1.08 |
| MBT88-8N-3    | 1/2       | 1/2       | 1/2       | .38     | 3.74 | 1.65 | 1.65 | 1.17 |
| MBT88-12N-3   | 1/2       | 1/2       | 3/4       | .38     | 3.74 | 1.65 | 1.65 | 1.35 |
| MBT1212-4N-3  | 3/4       | 3/4       | 1/4       | .25     | 4.44 | 1.99 | 1.99 | 1.27 |
| MBT1212-8N-3  | 3/4       | 3/4       | 1/2       | .51     | 4.44 | 1.99 | 1.99 | 1.35 |
| MBT1212-12N-3 | 3/4       | 3/4       | 3/4       | .63     | 4.44 | 1.99 | 1.99 | 1.35 |
| MBT1616-4N-3  | 1         | 1         | 1/4       | .25     | 5.40 | 2.43 | 2.43 | 1.57 |
| MBT1616-6N-3  | 1         | 1         | 3/8       | .38     | 5.40 | 2.43 | 2.43 | 1.54 |
| MBT1616-8N-3  | 1         | 1         | 1/2       | .51     | 5.40 | 2.43 | 2.43 | 1.63 |
| MBT1616-12N-3 | 1         | 1         | 3/4       | .69     | 5.40 | 2.43 | 2.43 | 1.63 |
| MBT1616-16N-3 | 1         | 1         | 1         | .88     | 5.40 | 2.43 | 2.43 | 1.81 |
| MBT2020-8N-3  | 1-1/4     | 1-1/4     | 1/2       | .51     | 5.92 | 2.65 | 2.65 | 2.00 |

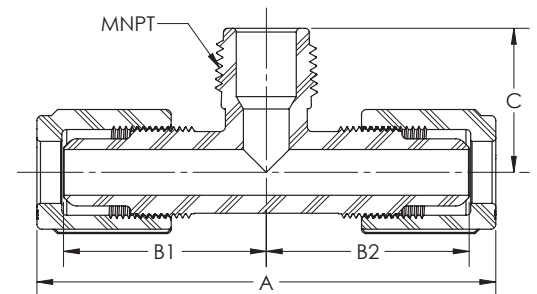

| Female Run Tee<br>(Male Flare x Male Flare x FNPT) |           |           |           |         |      |      |
|--|-----------|-----------|-----------|---------|------|------|
| PFA Part No.                                       | Tube O.D. | Tube O.D. | FNPT Size | Orifice | A    | B    |
| FRT1212-12N-3                                      | 3/4       | 3/4       | 3/4       | .63     | 3.75 | 1.99 |

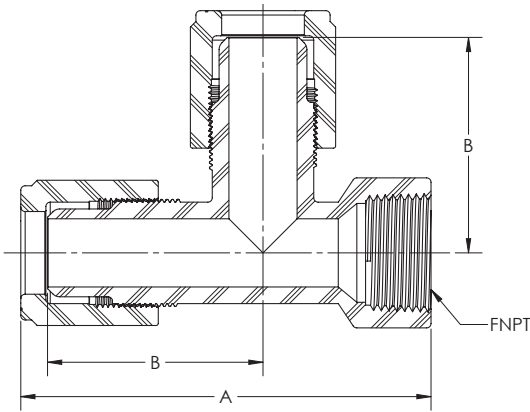

| Female Branch Tee<br>(Male Flare x FNPT x Male Flare) |           |     |         |      |      |      |
|---|-----------|-----|---------|------|------|------|
| PFA Part No.  | Tube O.D. | NPT | Orifice | A    | B    | C    |
| FBT88-4N-3  | 1/2       | 1/4 | .38     | 3.72 | 1.66 | 1.11 |
| FBT1212-4N-3  | 3/4       | 1/4 | .38     | 4.44 | 1.99 | 1.32 |
| FBT1212-12N-3   | 3/4       | 3/4 | .63     | 4.44 | 1.99 | 1.53 |
| FBT1616-4N-3  | 1         | 1/4 | .38     | 5.40 | 2.43 | 1.43 |
| FBT1616-8N-3  | 1         | 1/2 | .51     | 5.40 | 2.43 | 1.38 |

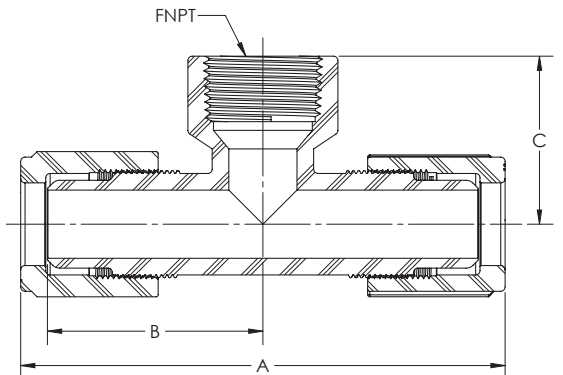

| Flare Plug and Nut<br>(Male Flare) |           |      |        |                               |      |      |        |
|------------------------------------|-----------|------|--------|-------------------------------|------|------|--------|
| PFA Flare Plug Part No.            | Tube O.D. | A    | Hex    | PFA Flare Plug & Nut Part No. | A    | B    | Hex    |
| FP4                                | 1/4       | 1.25 | 5/8    | FP4N-3                        | 1.47 | .70  | 5/8    |
| FP6                                | 3/8       | 1.34 | 13/16  | FP6N-3                        | 1.57 | .92  | 13/16  |
| FP8                                | 1/2       | 1.43 | 15/16  | FP8N-3                        | 1.67 | 1.04 | 15/16  |
| FP12                               | 3/4       | 1.58 | 1-3/16 | FP12N-3                       | 1.79 | 1.32 | 1-3/16 |
| FP16                               | 1         | 1.75 | 1-7/16 | FP16N-3                       | 2.01 | 1.60 | 1-7/16 |
| FP20                               | 1-1/4     | 2.13 | 1-3/4  | FP20N-3                       | 2.63 | 1.96 | 1-3/4  |

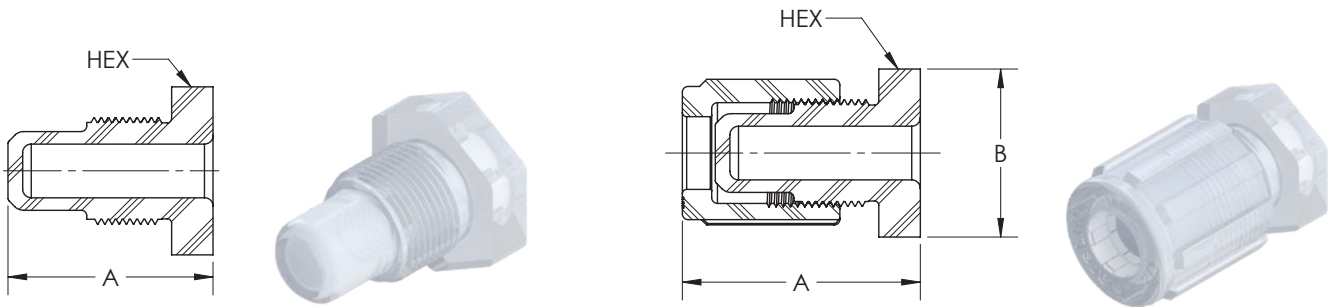

| Flare Cap<br>(Female Flare) |            |      |      |
|-----------------------------|------------|------|------|
| PFA Part No.                | Flare Size | A    | B    |
| FCAP4                       | 1/4        | .71  | .39  |
| FCAP6                       | 3/8        | .84  | .53  |
| FCAP8                       | 1/2        | .92  | .68  |
| FCAP12                      | 3/4        | 1.04 | .93  |
| FCAP16                      | 1          | 1.20 | 1.26 |
| FCAP20                      | 1-1/4      | 1.77 | 1.57 |

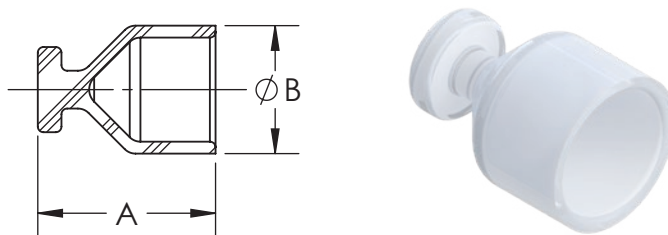

### Flare Nut PFA

| PFA Part No. | Tube O.D. | A    | B    |
|--------------|-----------|------|------|
| N4-3         | 1/4       | 1.02 | .84  |
| N6-3         | 3/8       | 1.03 | .99  |
| N8-3         | 1/2       | 1.12 | 1.07 |
| N12-3        | 3/4       | 1.27 | 1.41 |
| N16-3        | 1         | 1.51 | 1.85 |
| N20-3        | 1-1/4     | 1.86 | 2.32 |

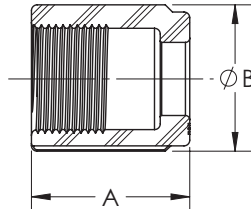

### Panel Mount Nut (Half Nut) PFA

| PFA Part No. | Hex   | A   | B            |
|--------------|-------|-----|--------------|
| PMN4-3       | 13/16 | .29 | 1/2-20 UNF   |
| PMN6-3       | 1     | .29 | 5/8-20 UN    |
| PMN8-3       | 1-1/8 | .30 | 3/4-20 UNEF  |
| PMN12-3      | 1-3/8 | .32 | 1-20 UNEF    |
| PMN16-3      | 1-7/8 | .34 | 1-7/16-12 UN |

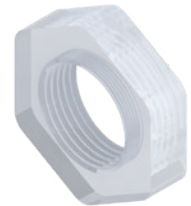
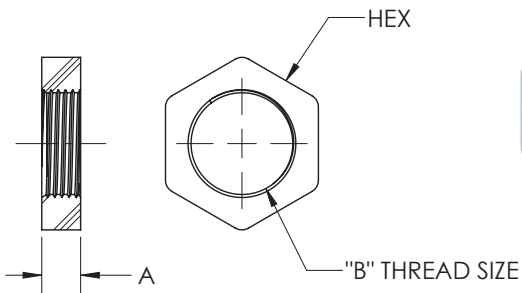

### Reduced Orifice Fittings (Straight Union) (Male Flare x Male Flare)

| PFA Part No. | Tube O.D. | Orifice | A    | B   | Hex   |
|--------------|-----------|---------|------|-----|-------|
| SU44N-3x.030 | 1/4       | .030    | 2.65 | .99 | 11/16 |

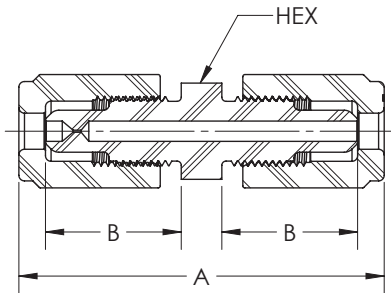

### Reduced Orifice Fittings (Male Connector) (Male Flare x MNPT)

| PFA Part No.  | Tube O.D. | MNPT Size | Orifice | A    | B   | C   | Hex |
|---------------|-----------|-----------|---------|------|-----|-----|-----|
| MC4-2N-3x.030 | 1/4       | 1/8       | .030    | 1.92 | .99 | .45 | 5/8 |
| MC4-2N-3x.015 | 1/4       | 1/8       | .015    | 1.92 | .99 | .45 | 5/8 |

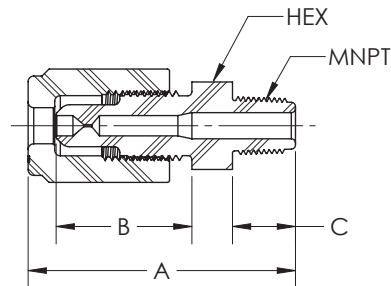

### Pipe Plug

| PFA Part No. | MNPT Size | A    | Hex    |
|--------------|-----------|------|--------|
| PP2          | 1/8       | .80  | 1/2    |
| PP4          | 1/4       | .85  | 5/8    |
| PP6          | 3/8       | .85  | 11/16  |
| PP8          | 1/2       | .96  | 13/16  |
| PP12         | 3/4       | .96  | 1-3/16 |
| PP16         | 1         | 1.14 | 1-7/16 |

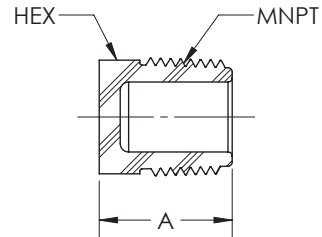

### Pipe Nipple

| PFA Part No. | MNPT Size | A    | Hex    |
|--------------|-----------|------|--------|
| PN2          | 1/8       | 1.31 | 1/2    |
| PN4          | 1/4       | 1.41 | 5/8    |
| PN6          | 3/8       | 1.41 | 11/16  |
| PN8          | 1/2       | 1.61 | 13/16  |
| PN12         | 3/4       | 1.67 | 1-3/16 |
| PN16         | 1         | 2.01 | 1-7/16 |

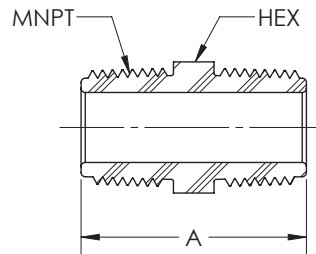

### Female Male Connector Reducer

| PFA Part No. | FNPT | MNPT Size | A    | Hex    |
|--------------|------|-----------|------|--------|
| FMCR4-8      | 1/4  | 1/2       | 1.29 | 13/16  |
| FMCR6-8      | 3/8  | 1/2       | 1.38 | 15/16  |
| FMCR8-12     | 1/2  | 3/4       | 1.53 | 1-3/16 |

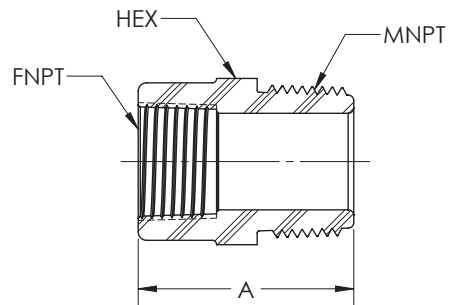

# GrabLOC Double Containment Fittings (Non-Terminating)

**PMBP series** panel mount fittings allow the primary and secondary tubes to pass through the fitting body. This allows chemistry to flow back to the supply source if the primary tube leaks.

| Part No.    | Secondary Containment Tubing | A    | B    | C   | D   | Panel Mount Hole | Primary Tubing Sizes |
|-------------|------------------------------|------|------|-----|-----|------------------|----------------------|
| PMBP8GLN-1  | 1/2                          | 2.79 | 1.11 | .29 | .50 | 1-1/4            | 1/4                  |
| PMBP12GLN-1 | 3/4                          | 3.01 | 1.13 | .38 | .50 | 1-1/2            | 1/2, 3/8, 1/4        |
| PMBP16GLN-1 | 1                            | 3.47 | 1.27 | .38 | .50 | 2                | 3/4, 1/2, 3/8, 1/4   |

### Features

- PFA Fitting Body
- PVDF Nut

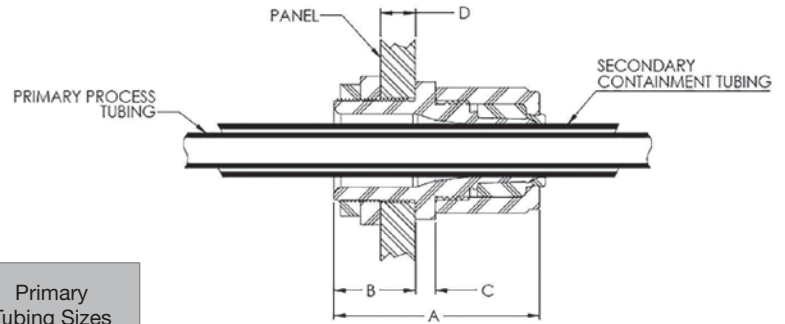

Tubing not included. Shown for clarity only.

**MCBP series** fittings are used on a box or cabinet that have a female NPT. The primary and secondary tubing pass through the fitting body. This allows chemistry to flow back to the supply source if the primary tube leaks.

| Part No.       | Secondary Containment Tubing | Male National Pipe Thread (MNPT) | A    | B   | C   | Primary Tubing Sizes |
|----------------|------------------------------|----------------------------------|------|-----|-----|----------------------|
| MCBP8GL-12N-1  | 1/2                          | 3/4                              | 2.35 | .67 | .29 | 1/4                  |
| MCBP12GL-16N-1 | 3/4                          | 1                                | 2.73 | .85 | .38 | 1/2, 3/8, 1/4        |
| MCBP16GL-20N-1 | 1                            | 1-1/4                            | 3.07 | .86 | .38 | 3/4, 1/2, 3/8, 1/4   |

### Features

- PFA Fitting Body
- PVDF Nut
- MNPT Connection

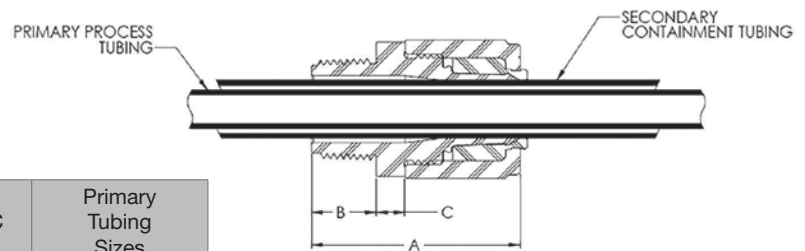

Tubing not included. Shown for clarity only.

| Part No. | Nut Size |
|----------|----------|
| DCW8-1   | 1/2      |
| DCW12-1  | 3/4      |
| DCW16-1  | 1        |
| DCW20-1  | 1-1/4    |

### GrabLOC Wrenches

- Ratcheting action
- Allows nuts to be rapidly tightened.
- Fits easily in the palm of your hand.



# GrabLOC Double Containment Fittings (Terminating)

**PMDC series** fittings are a conventional panel mount connection. The primary tubing passes through the fitting body with a simple push-on secondary tube terminating the tube connection. There is no flaring required of the secondary tube.

| Part No.      | Primary Process Tubing | Secondary Containment Tubing | A    | B    | C   | D   | Panel Mount Hole |
|---------------|------------------------|------------------------------|------|------|-----|-----|------------------|
| PMDC48GLN-1   | 1/4                    | 1/2                          | 2.62 | 1.10 | .29 | .50 | 1                |
| PMDC612GLN-1  | 3/8                    | 3/4                          | 2.79 | 1.11 | .29 | .50 | 1-1/4            |
| PMDC812GLN-1  | 1/2                    | 3/4                          | 2.79 | 1.11 | .29 | .50 | 1-1/4            |
| PMDC816GLN-1  | 1/2                    | 1                            | 3.36 | 1.57 | .29 | .50 | 1-1/2            |
| PMDC1216GLN-1 | 3/4                    | 1                            | 3.01 | 1.13 | .38 | .50 | 1-1/2            |
| PMDC1620GLN-1 | 1                      | 1-1/4                        | 3.47 | 1.27 | .38 | .50 | 2                |

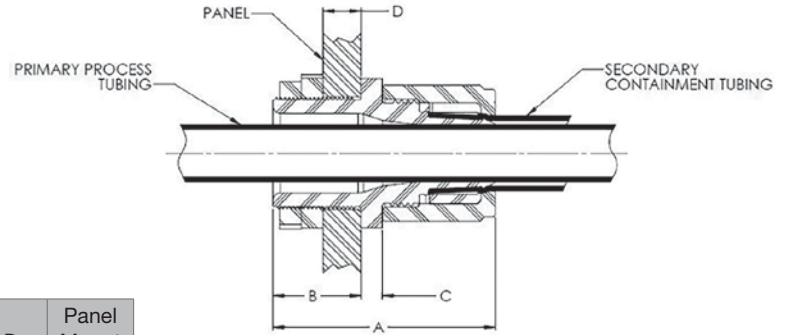

Tubing not included. Shown for clarity only.

### Features

- PFA Fitting Body
- PVDF Nut

**MCDC series** fittings are used on a box or cabinet that have a female NPT. The primary tubing passes through the fitting body with a simple push-on secondary tubing terminating the tube connection. There is no flaring required of the secondary tube.

| Part No.         | Primary Process Tubing | Secondary Containment Tubing | Male National Pipe Thread ( MNPT) | A    | B   | C   |
|------------------|------------------------|------------------------------|-----------------------------------|------|-----|-----|
| MCDC48GL-8N-1    | 1/4                    | 1/2                          | 1/2                               | 2.17 | .66 | .29 |
| MCDC612GL-12N-1  | 3/8                    | 3/4                          | 3/4                               | 2.35 | .67 | .29 |
| MCDC812GL-12N-1  | 1/2                    | 3/4                          | 3/4                               | 2.35 | .67 | .29 |
| MCDC816GL-16N-1  | 1/2                    | 1                            | 1                                 | 2.73 | .85 | .38 |
| MCDC1216GL-16N-1 | 3/4                    | 1                            | 1                                 | 2.73 | .85 | .38 |
| MCDC1620GL-20N-1 | 1                      | 1-1/4                        | 1-1/4                             | 3.07 | .86 | .38 |

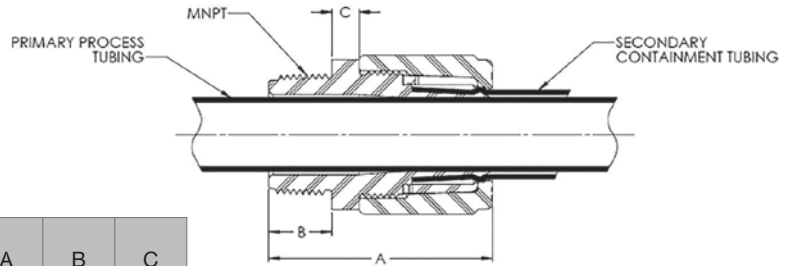

Tubing not included. Shown for clarity only.

### Features

- PFA Fitting Body
- PVDF Nut
- MNPT Connection

# GrabLOC Double Containment Tee

Patent Pending

| Part No.           | Secondary Containment Tubing | Recovery Tubing | Primary Process Tubing |
|--------------------|------------------------------|-----------------|------------------------|
| GLT8BP-8-4BPN-1    | 1/2                          | 1/2             | 1/4                    |
| GLT12BP-12-8BPN-1  | 3/4                          | 3/4             | 1/2                    |
| GLT16BP-12-8BPN-1  | 1                            | 3/4             | 1/2                    |
| GLT16BP-16-12BPN-1 | 1                            | 1               | 3/4                    |

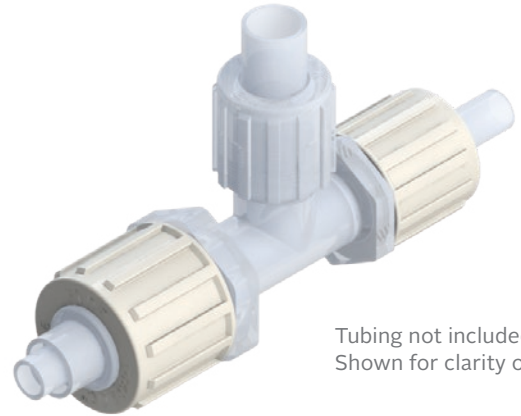

Tubing not included. Shown for clarity only.

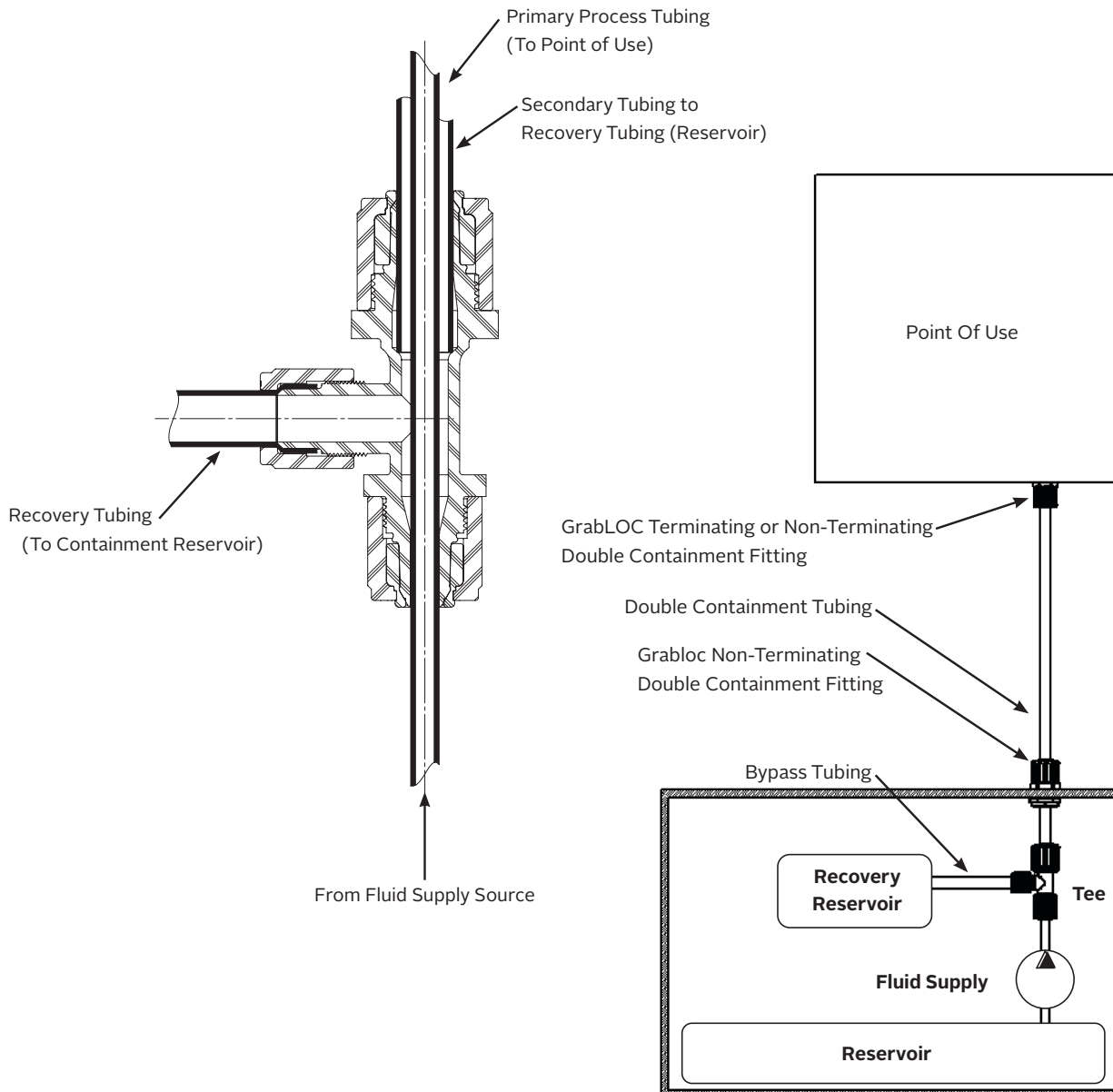

**Weld Straight Connector**  
(Pipe x Male Flare)

| PFA Part No. | Pipe Size | Tube Size | Orifice | A    | B    | C    | D    | E    | Hex    |
|--------------|-----------|-----------|---------|------|------|------|------|------|--------|
| WSC4P-4N-3   | 1/4       | 1/4       | .15     | 2.02 | .54  | .35  | .55  | 1.83 | 5/8    |
| WSC4P-6N-3   | 1/4       | 3/8       | .25     | 2.12 | .54  | .35  | .55  | 1.89 | 13/16  |
| WSC4P-8N-3   | 1/4       | 1/2       | .35     | 2.21 | .54  | .35  | .55  | 1.99 | 13/16  |
| WSC8P-4N-3   | 1/2       | 1/4       | .15     | 3.15 | .84  | .61  | 1.50 | 2.96 | 1      |
| WSC8P-6N-3   | 1/2       | 3/8       | .25     | 3.26 | .84  | .61  | 1.50 | 3.03 | 1      |
| WSC8P-8N-3   | 1/2       | 1/2       | .38     | 3.36 | .84  | .61  | 1.50 | 3.14 | 1      |
| WSC8P-12N-3  | 1/2       | 3/4       | .61     | 3.50 | .84  | .61  | 1.50 | 3.27 | 1-3/16 |
| WSC12P-4N-3  | 3/4       | 1/4       | .15     | 3.15 | 1.05 | .81  | 1.50 | 2.96 | 1-3/16 |
| WSC12P-6N-3  | 3/4       | 3/8       | .25     | 3.26 | 1.05 | .81  | 1.50 | 3.03 | 1-3/16 |
| WSC12P-8N-3  | 3/4       | 1/2       | .38     | 3.36 | 1.05 | .81  | 1.50 | 3.14 | 1-3/16 |
| WSC12P-12N-3 | 3/4       | 3/4       | .63     | 3.50 | 1.05 | .81  | 1.50 | 3.27 | 1-3/16 |
| WSC12P-16N-3 | 3/4       | 1         | .81     | 3.71 | 1.05 | .81  | 1.50 | 3.44 | 1-7/16 |
| WSC16P-8N-3  | 1         | 1/2       | .38     | 2.63 | 1.32 | 1.05 | 1.50 | 2.41 | 1-7/16 |
| WSC16P-12N-3 | 1         | 3/4       | .63     | 3.50 | 1.32 | 1.03 | 1.50 | 3.27 | 1-7/16 |
| WSC16P-16N-3 | 1         | 1         | .88     | 3.71 | 1.32 | 1.03 | 1.50 | 3.44 | 1-7/16 |

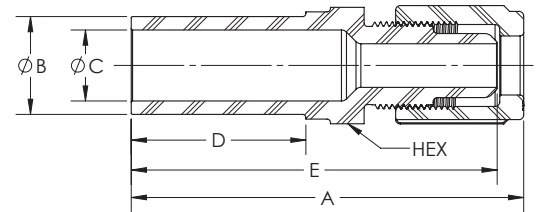

**Weld Straight Connector (TightFLARE)**  
(Pipe x Female Flare)

| PFA Part No.  | Pipe Size | TightFLARE | Orifice | A    | B    | C    | D    | E    |
|---------------|-----------|------------|---------|------|------|------|------|------|
| WSC4P-4TN-3   | 1/4       | 1/4        | .15     | 2.17 | .54  | .35  | .55  | 1.40 |
| WSC4P-6TN-3   | 1/4       | 3/8        | .25     | 2.21 | .54  | .35  | .55  | 1.36 |
| WSC8P-6TN-3   | 1/2       | 3/8        | .25     | 3.38 | .84  | .61  | 1.50 | 2.53 |
| WSC8P-8TN-3   | 1/2       | 1/2        | .38     | 3.42 | .84  | .61  | 1.50 | 2.52 |
| WSC8P-12TN-3  | 1/2       | 3/4        | .61     | 3.58 | .84  | .61  | 1.50 | 2.53 |
| WSC12P-8TN-3  | 3/4       | 1/2        | .38     | 3.42 | 1.05 | .81  | 1.50 | 2.52 |
| WSC12P-12TN-3 | 3/4       | 3/4        | .63     | 3.58 | 1.05 | .81  | 1.50 | 2.53 |
| WSC12P-16TN-3 | 3/4       | 1          | .81     | 4.02 | 1.05 | .81  | 1.50 | 2.68 |
| WSC16P-8TN-3  | 1         | 1/2        | .38     | 3.42 | 1.32 | 1.03 | 1.50 | 2.52 |
| WSC16P-12TN-3 | 1         | 3/4        | .63     | 3.58 | 1.32 | 1.03 | 1.50 | 2.53 |
| WSC16P-16TN-3 | 1         | 1          | .88     | 4.02 | 1.32 | 1.03 | 1.50 | 2.68 |
| WSC16P-20TN-3 | 1         | 1-1/4      | 1.03    | 4.44 | 1.32 | 1.03 | 1.50 | 3.14 |

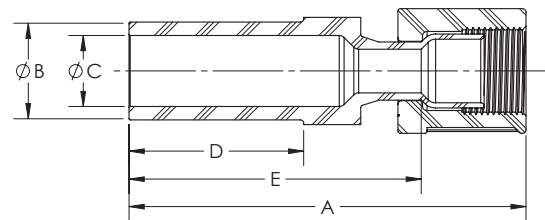

| Weld Elbow Connector<br>(Pipe x Male Flare) |           |           |         |      |      |      |      |      |      |
|---|-----------|-----------|---------|------|------|------|------|------|------|
| PFA Part No.                                | Pipe Size | Tube Size | Orifice | A    | B    | C    | D    | E    | F    |
| WEC4P-4N-3                                  | 1/4       | 1/4       | .15     | 1.27 | .54  | .35  | .75  | 1.47 | 1.66 |
| WEC4P-6N-3                                  | 1/4       | 3/8       | .25     | 1.27 | .54  | .35  | .75  | 1.53 | 1.76 |
| WEC8P-4N-3                                  | 1/2       | 1/4       | .15     | 1.44 | .84  | .61  | .75  | 1.47 | 1.66 |
| WEC8P-6N-3                                  | 1/2       | 3/8       | .25     | 1.44 | .84  | .61  | .75  | 1.53 | 1.76 |
| WEC8P-8N-3                                  | 1/2       | 1/2       | .38     | 1.44 | .84  | .61  | .75  | 1.65 | 1.87 |
| WEC8P-12N-3                                 | 1/2       | 3/4       | .61     | 1.50 | .84  | .61  | .79  | 1.99 | 2.22 |
| WEC12P-4N-3                                 | 3/4       | 1/4       | .15     | 1.71 | 1.05 | .81  | .84  | 1.47 | 1.66 |
| WEC12P-8N-3                                 | 3/4       | 1/2       | .38     | 1.71 | 1.05 | .81  | .84  | 1.65 | 1.87 |
| WEC12P-12N-3                                | 3/4       | 3/4       | .63     | 1.71 | 1.05 | .81  | .84  | 1.99 | 2.22 |
| WEC12P-16N-3                                | 3/4       | 1         | .63     | 1.71 | 1.05 | .81  | 1.05 | 2.43 | 2.70 |
| WEC16P-8N-3                                 | 1         | 1/2       | .38     | 1.72 | 1.32 | 1.03 | .75  | 1.82 | 1.87 |
| WEC16P-12N-3                                | 1         | 3/4       | .63     | 1.72 | 1.32 | 1.03 | .75  | 1.99 | 2.22 |
| WEC16P-16N-3                                | 1         | 1         | .88     | 1.72 | 1.32 | 1.03 | .75  | 2.43 | 2.70 |

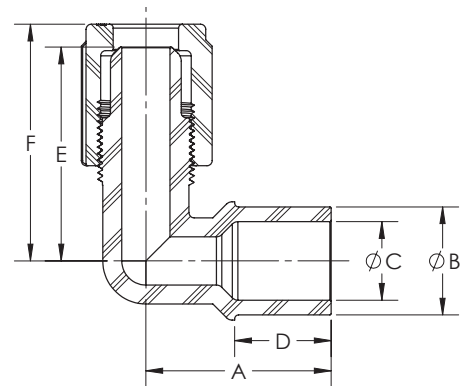

| Weld Elbow Connector (TightFLARE)<br>(Pipe x Female Flare) |           |            |         |      |      |      |      |      |      |
|--|-----------|------------|---------|------|------|------|------|------|------|
| PFA Part No.   | Pipe Size | TightFLARE | Orifice | A    | B    | C    | D    | E    | F    |
| WEC4P-4TN-3  | 1/4       | 1/4        | .15     | 1.27 | .54  | .35  | .75  | .87  | 1.64 |
| WEC4P-6TN-3  | 1/4       | 3/8        | .25     | 1.27 | .54  | .35  | .75  | .88  | 1.73 |
| WEC8P-4TN-3  | 1/2       | 1/4        | .15     | 1.44 | .84  | .61  | .75  | .87  | 1.64 |
| WEC8P-6TN-3  | 1/2       | 3/8        | .25     | 1.44 | .84  | .61  | .75  | .88  | 1.73 |
| WEC8P-8TN-3  | 1/2       | 1/2        | .38     | 1.44 | .84  | .61  | .75  | .94  | 1.84 |
| WEC8P-12TN-3   | 1/2       | 3/4        | .61     | 1.50 | .84  | .61  | .79  | 1.08 | 2.13 |
| WEC12P-8TN-3   | 3/4       | 1/2        | .38     | 1.71 | 1.05 | .81  | .84  | .94  | 1.84 |
| WEC12P-12TN-3  | 3/4       | 3/4        | .63     | 1.71 | 1.05 | .81  | .84  | 1.08 | 2.13 |
| WEC12P-16TN-3  | 3/4       | 1          | .81     | 1.71 | 1.05 | .81  | 1.05 | 1.40 | 2.74 |
| WEC16P-12TN-3  | 1         | 3/4        | .63     | 1.72 | 1.32 | 1.03 | .75  | 1.08 | 2.13 |
| WEC16P-16TN-3  | 1         | 1          | .88     | 1.72 | 1.32 | 1.03 | .75  | 1.40 | 2.74 |

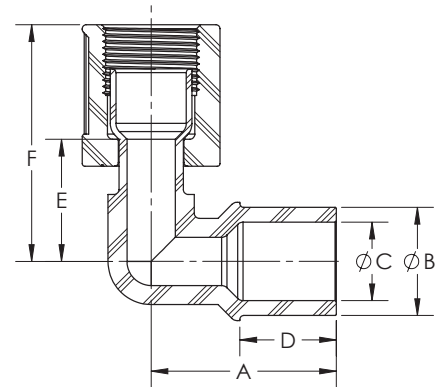

| Weld Straight Reducer<br>(Pipe x Pipe) |           |         |      |      |      |      |      |     |      |      |
|--|-----------|---------|------|------|------|------|------|-----|------|------|
| PFA Part No.                           | Pipe Size | Orifice | A    | B    | C    | D1   | D2   | E   | F    | G    |
| WSR8P4P                                | 1/2 x 1/4 | .35     | 2.75 | .84  | .61  | 1.50 | .75  | .35 | .54  | .83  |
| WSR12P4P                               | 3/4 x 1/4 | .35     | 2.75 | 1.05 | .81  | 1.50 | .75  | .35 | .54  | 1.11 |
| WSR12P8P                               | 3/4 x 1/2 | .61     | 3.50 | 1.05 | .81  | 1.50 | 1.50 | .61 | .84  | 1.11 |
| WSR16P4P                               | 1 x 1/4   | .35     | 3.50 | 1.32 | 1.03 | 1.50 | .75  | .35 | .54  | 1.41 |
| WSR16P8P                               | 1 x 1/2   | .61     | 3.50 | 1.32 | 1.03 | 1.50 | 1.50 | .61 | .84  | 1.41 |
| WSR16P12P                              | 1 x 3/4   | .81     | 3.50 | 1.32 | 1.03 | 1.50 | 1.50 | .81 | 1.05 | 1.41 |

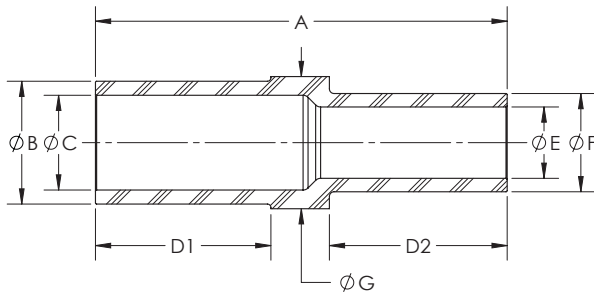

| Weld Pipe Cap<br>(Pipe) |           |      |      |      |      |      |
|-------------------------|-----------|------|------|------|------|------|
| PFA Part No.            | Pipe Size | A    | B    | C    | D    | E    |
| WCAP4                   | 1/4       | .75  | .54  | .35  | .55  | .62  |
| WCAP8                   | 1/2       | 2.00 | .84  | .61  | 1.49 | .90  |
| WCAP12                  | 3/4       | 2.01 | 1.05 | .81  | 1.49 | 1.11 |
| WCAP16                  | 1         | 2.01 | 1.32 | 1.03 | 1.49 | 1.43 |

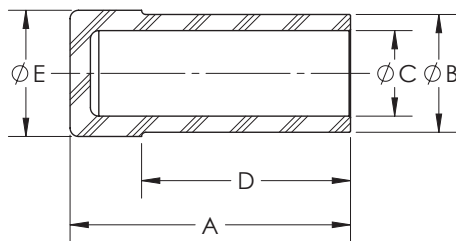

| Weld Union Elbow<br>(Pipe x Pipe) |           |      |      |      |      |
|-----------------------------------|-----------|------|------|------|------|
| PFA Part No.                      | Pipe Size | A    | B    | C    | D    |
| WUE4P                             | 1/4       | 1.27 | .54  | .35  | .75  |
| WUE8P                             | 1/2       | 1.47 | .84  | .61  | .75  |
| WUE8PX                            | 1/2       | 2.22 | .84  | .61  | 1.50 |
| WUE12P                            | 3/4       | 1.55 | 1.05 | .81  | .75  |
| WUE12PX                           | 3/4       | 2.30 | 1.05 | .81  | 1.50 |
| WUE16P                            | 1         | 1.50 | 1.32 | 1.03 | .75  |
| WUE16PX                           | 1         | 2.18 | 1.32 | 1.03 | 1.48 |

X = Extended

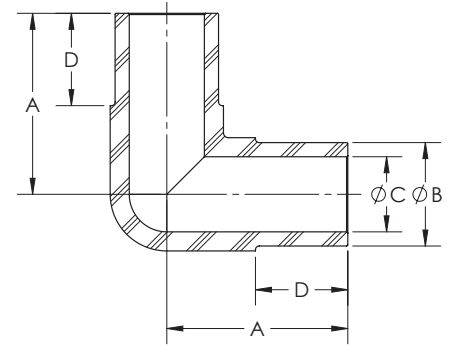

| Weld Union Tee<br>(Pipe x Pipe) |           |      |      |      |      |      |
|---------------------------------|-----------|------|------|------|------|------|
| PFA Part No.                    | Pipe Size | A    | B    | C    | D    | E    |
| WUT4P                           | 1/4       | 2.54 | .54  | .35  | .75  | 1.27 |
| WUT8P                           | 1/2       | 2.94 | .84  | .61  | .75  | 1.47 |
| WUT8PX                          | 1/2       | 4.44 | .84  | .61  | 1.50 | 2.22 |
| WUT12P                          | 3/4       | 3.10 | 1.05 | .81  | .75  | 1.55 |
| WUT12PX                         | 3/4       | 4.60 | 1.05 | .81  | 1.50 | 2.30 |
| WUT16P                          | 1         | 3.00 | 1.32 | 1.03 | .75  | 1.50 |
| WUT16PX                         | 1         | 4.36 | 1.32 | 1.03 | 1.48 | 2.18 |

X = Extended

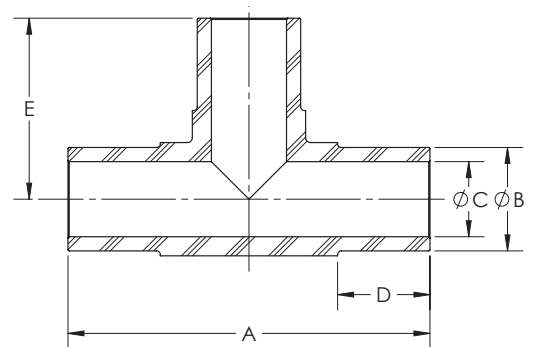

| Weld Male Adapter<br>(Pipe x MNPT) |           |           |         |      |      |      |      |        |
|------------------------------------|-----------|-----------|---------|------|------|------|------|--------|
| PFA Part No.                       | Pipe Size | MNPT Size | Orifice | A    | B    | C    | D    | Hex    |
| WMA4P-4                            | 1/4       | 1/4       | .28     | 1.39 | .54  | .35  | .55  | 5/8    |
| WMA8P-6                            | 1/2       | 3/8       | .36     | 2.56 | .84  | .61  | 1.49 | 1      |
| WMA8P-8                            | 1/2       | 1/2       | .51     | 2.66 | .84  | .61  | 1.49 | 1      |
| WMA12P-8                           | 3/4       | 1/2       | .51     | 2.66 | .84  | .61  | 1.49 | 1-3/16 |
| WMA12P-12                          | 3/4       | 3/4       | .66     | 2.68 | 1.05 | .81  | 1.49 | 1-3/16 |
| WMA16P-16                          | 1         | 1         | .94     | 2.85 | 1.32 | 1.03 | 1.49 | 1-7/16 |

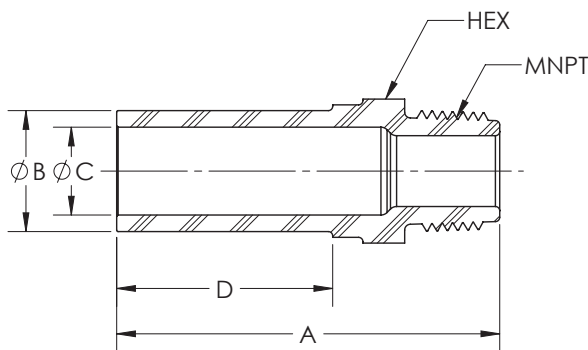

| Weld Female Adapter<br>(Pipe x FNPT) |           |           |         |      |      |      |      |        |
|--------------------------------------|-----------|-----------|---------|------|------|------|------|--------|
| PFA Part No.                         | Pipe Size | FNPT Size | Orifice | A    | B    | C    | D    | Hex    |
| WFA4P-4                              | 1/4       | 1/4       | .34     | 1.58 | .54  | .35  | .75  | 3/4    |
| WFA8P-6                              | 1/2       | 3/8       | .36     | 2.49 | .84  | .35  | 1.49 | 1      |
| WFA8P-8                              | 1/2       | 1/2       | .51     | 2.56 | .84  | .61  | 1.49 | 1-3/16 |
| WFA12P-12                            | 3/4       | 3/4       | .79     | 2.69 | 1.05 | .81  | 1.49 | 1-7/16 |
| WFA16P-16                            | 1         | 1         | .99     | 2.83 | 1.32 | 1.03 | 1.49 | 1-5/8  |

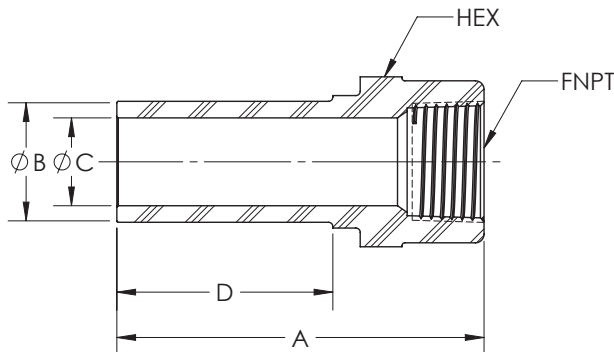

| Weld Straight Reducer<br>(Tube x Tube) |           |      |     |           |           |     |
|--|-----------|------|-----|-----------|-----------|-----|
| PFA Part No.                           | Tube OD   | A    | B   | C Orifice | D Orifice | E   |
| WSR6TS4TS                              | 3/8 x 1/4 | 1.63 | .55 | .25       | .15       | .83 |
| WSR8TS4TS                              | 1/2 x 1/4 | 1.63 | .55 | .38       | .15       | .83 |
| WSR8TS6TS                              | 1/2 x 3/8 | 1.53 | .55 | .38       | .25       | .73 |
| WSR12TS4TS                             | 3/4 x 1/4 | 1.63 | .55 | .63       | .15       | .83 |
| WSR12TS6TS                             | 3/4 x 3/8 | 1.53 | .55 | .63       | .25       | .73 |
| WSR12TS8TS                             | 3/4 x 1/2 | 1.63 | .55 | .63       | .38       | .83 |
| WSR16TS4TS                             | 1 x 1/4   | 1.58 | .55 | .88       | .15       | .78 |
| WSR16TS6TS                             | 1 x 3/8   | 1.53 | .55 | .88       | .25       | .73 |
| WSR16TS8TS                             | 1 x 1/2   | 1.63 | .55 | .88       | .38       | .83 |
| WSR16TS12TS                            | 1 x 3/4   | 1.54 | .55 | .88       | .63       | .74 |
| WSR20TS16TS                            | 1-1/4 x 1 | 1.66 | .76 | 1.10      | .88       | .65 |

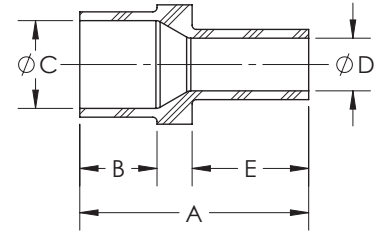

| Weld Elbow<br>(Tube x Tube) |         |      |      |           |
|-----------------------------|---------|------|------|-----------|
| PFA Part No.                | Tube OD | A    | B    | C Orifice |
| WE4TS                       | 1/4     | 1.33 | .81  | .15       |
| WE6TS                       | 3/8     | 1.42 | .90  | .25       |
| WE8TS                       | 1/2     | 1.68 | 1.16 | .38       |
| WE12TS                      | 3/4     | 1.87 | 1.18 | .63       |
| WE16TS                      | 1       | 2.31 | 1.36 | .88       |
| WE20TS                      | 1-1/4   | 2.56 | 1.62 | 1.10      |

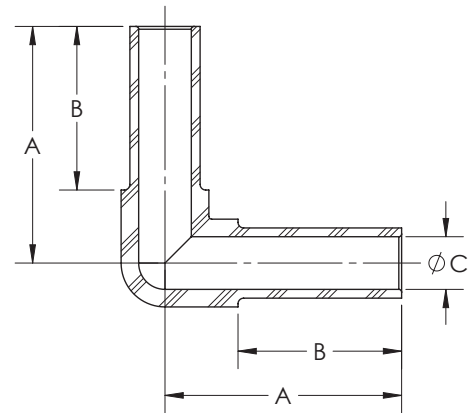

| Weld Elbow Reducer<br>(Tube x Tube) |           |      |      |           |           |      |      |
|-------------------------------------|-----------|------|------|-----------|-----------|------|------|
| PFA Part No.                        | Tube OD   | A    | B    | C Orifice | D Orifice | E    | F    |
| WE6TS4TS                            | 3/8 x 1/4 | 1.42 | .90  | .25       | .15       | 1.33 | .81  |
| WE8TS4TS                            | 1/2 x 1/4 | 1.68 | 1.16 | .38       | .15       | 1.33 | .81  |
| WE8TS6TS                            | 1/2 x 3/8 | 1.68 | 1.16 | .38       | .25       | 1.42 | .90  |
| WE12TS8TS                           | 3/4 x 1/2 | 1.87 | 1.18 | .63       | .38       | 1.68 | 1.16 |
| WE16TS8TS                           | 1 x 1/2   | 2.31 | 1.36 | .88       | .38       | 1.68 | 1.16 |
| WE16TS12TS                          | 1 x 3/4   | 2.31 | 1.36 | .88       | .63       | 1.87 | 1.18 |

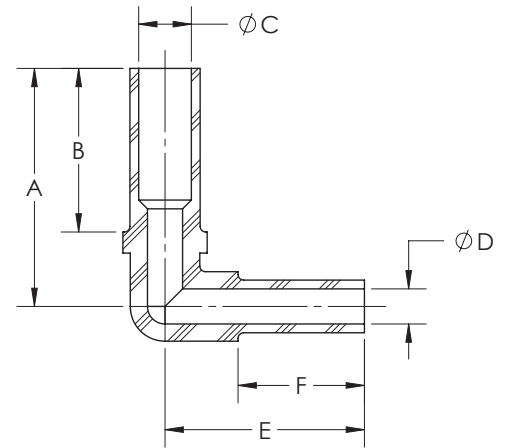

| Weld Elbow Sweep<br>(Tube x Tube) |         |      |      |           |
|-----------------------------------|---------|------|------|-----------|
| PFA Part No.                      | Tube OD | A    | B    | C Orifice |
| WES4TS                            | 1/4     | 1.41 | .60  | .15       |
| WES6TS                            | 3/8     | 1.61 | .70  | .25       |
| WES8TS                            | 1/2     | 1.79 | .80  | .38       |
| WES12TS                           | 3/4     | 2.17 | .92  | .63       |
| WES16TS                           | 1       | 2.75 | 1.08 | .88       |

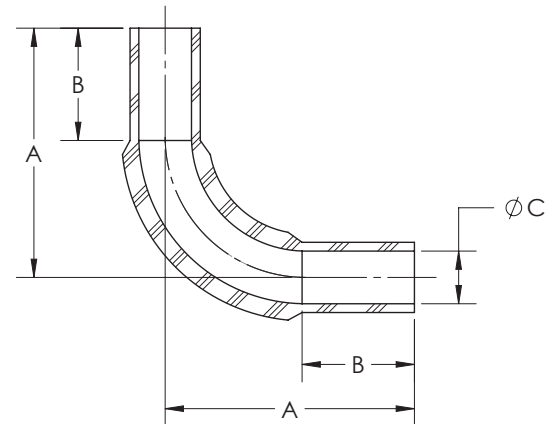

| Weld Tee<br>(Tube x Tube x Tube) |         |      |      |           |      |
|----------------------------------|---------|------|------|-----------|------|
| PFA Part No.                     | Tube OD | A    | B    | C Orifice | D    |
| WT4TS                            | 1/4     | 2.66 | .81  | .15       | 1.33 |
| WT6TS                            | 3/8     | 2.82 | .90  | .25       | 1.41 |
| WT8TS                            | 1/2     | 3.37 | 1.16 | .38       | 1.68 |
| WT12TS                           | 3/4     | 3.74 | 1.18 | .63       | 1.87 |
| WT16TS                           | 1       | 4.62 | 1.36 | .88       | 2.31 |
| WT20TS                           | 1-1/4   | 5.12 | 1.62 | 1.1       | 2.56 |

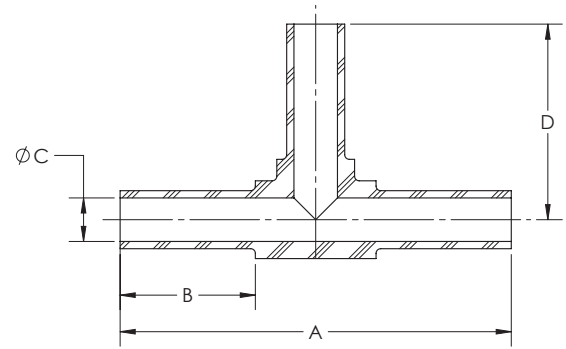

| Weld Tee Reducer<br>(Tube x Tube x Tube) |       |      |       |      |      |           |           |      |
|--|-------|------|-------|------|------|-----------|-----------|------|
| PFA Part No.                             | X OD  | Y OD | Z OD  | A    | B    | C Orifice | D Orifice | E    |
| WT6TS-4TS-6TS                            | 3/8   | 1/4  | 3/8   | 2.82 | .90  | .25       | .15       | 1.33 |
| WT8TS-4TS-8TS                            | 1/2   | 1/4  | 1/2   | 3.37 | 1.16 | .38       | .15       | 1.33 |
| WT8TS-6TS-8TS                            | 1/2   | 3/8  | 1/2   | 3.37 | 1.16 | .38       | .25       | 1.41 |
| WT12TS-4TS-12TS                          | 3/4   | 1/4  | 3/4   | 3.74 | 1.18 | .63       | .15       | 1.33 |
| WT12TS-6TS-12TS                          | 3/4   | 3/8  | 3/4   | 3.74 | 1.18 | .63       | .25       | 1.41 |
| WT12TS-8TS-12TS                          | 3/4   | 1/2  | 3/4   | 3.74 | 1.18 | .63       | .38       | 1.68 |
| WT16TS-8TS-16TS                          | 1     | 1/2  | 1     | 4.62 | 1.36 | .88       | .38       | 1.68 |
| WT16TS-12TS-16TS                         | 1     | 3/4  | 1     | 4.62 | 1.36 | .88       | .63       | 1.87 |
| WT20TS-16TS-20TS                         | 1-1/4 | 1    | 1-1/4 | 5.12 | 1.62 | 1.10      | .88       | 2.56 |

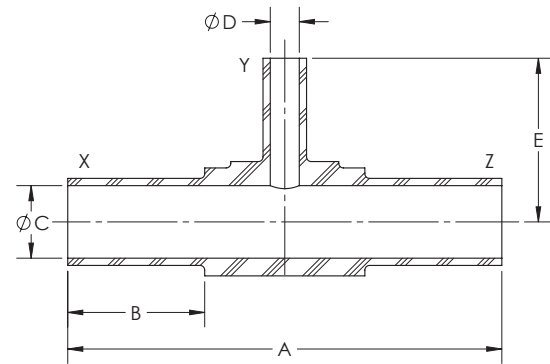

| Weld Cross<br>(All Tube) |         |      |      |     |
|--------------------------|---------|------|------|-----|
| PFA Part No.             | Tube OD | A    | B    | C   |
| WX4TS                    | 1/4     | 1.75 | .16  | .50 |
| WX6TS                    | 3/8     | 1.75 | .25  | .50 |
| WX8TS                    | 1/2     | 1.75 | .38  | .50 |
| WX20TS                   | 1-1/4   | 2.64 | 1.10 | .63 |

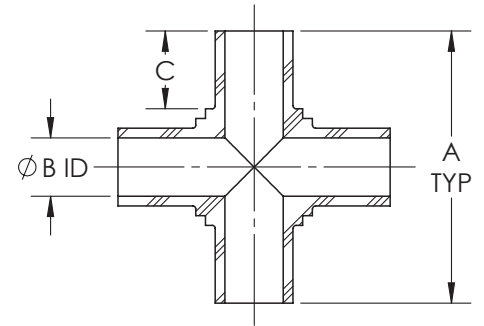

| Weld Cross Reducer<br>(All Tube) |           |      |      |     |     |     |     |
|----------------------------------|-----------|------|------|-----|-----|-----|-----|
| PFA Part No.                     | Tube OD   | A    | B    | C   | D   | E   | F   |
| WX6TS4TS                         | 3/8 X 1/4 | 1.75 | 1.75 | .25 | .16 | .50 | .50 |
| WX8TS6TS                         | 1/2 X 3/8 | 1.75 | 1.75 | .38 | .25 | .50 | .50 |
| WX12TS8TS                        | 3/4 X 1/2 | 2.00 | 2.00 | .63 | .38 | .49 | .49 |
| WX16TS12TS                       | 1 X 3/4   | 2.06 | 2.20 | .88 | .63 | .45 | .51 |

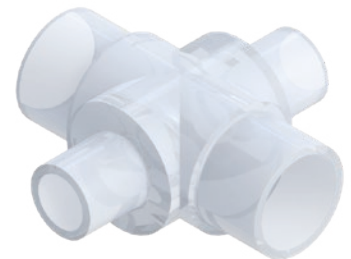
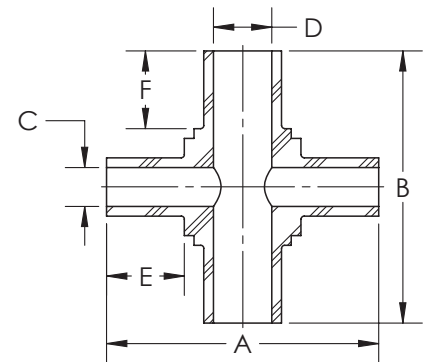

# Flare Link™

## TUBE ASSEMBLY SYSTEM

The versatile Tube Assembly System is ideal for both in-house production and job site flaring.

The patented heaters apply uniform heat around the tube to a controlled and repeatable length. Once the heat cycle is complete, the tube end is installed over the forming mandrel. The mandrels are engineered to extract heat evenly from the flared tube end. Applying controlled, uniform heat and extracting it evenly creates a stress-free “formed” flared end. This gives end users the flexibility to flare their tubes days in advance or quickly and consistently at the job site.



### KEY FEATURES

- Versatile flaring system, ideal for in-house production and job site flaring.
- Creates precise, concentric, repeatable tube flare ends.
- Automated touchscreen interface with preprogrammed tube settings.
- 15' long heater cord allows flaring in hard-to-reach places.
- Exceptionally user-friendly.

| Flare Link<br>Tube Assembly System<br>Patented |              |
|--|--------------|
| Input Voltage                                  | Part No.     |
| 110V   | MTF416-110-A |
| 220V   | MTF416-220-A |



# Flare Link™

## TORQUE WRENCH SYSTEM

Fastens PFA nuts to the required torque value which ensures leak-free flared fitting assemblies.

### KEY FEATURES

- Wrenches are calibrated to preset torque values based on nut size.
- Wrench claw clicks over when required torque value is reached.
- Ratcheting action allows the nut to be rapidly tightened, making jobs easier and faster.
- Wrenches fit in the palm of a hand easily allowing use in hard to reach places.
- Available for PFA nuts.
- U.S. and foreign patents pending.

| Flare Link<br>Torque Wrenches<br>Patent Pending |              |
|---|--------------|
| Nut Size  | PFA Part No. |
| 1/4"  | TFW4-3       |
| 3/8"  | TFW6-3       |
| 1/2"  | TFW8-3       |
| 3/4"  | TFW12-3      |
| 1"  | TFW16-3      |
| Complete Set<br><i>(All sizes listed above)</i> | TFWS-3       |



#### RATCHETING ACTION

Rapidly tighten nuts to make assemblies easier and faster.



#### CLICK OVER FEATURE

The claw clicks over when wrench reaches required torque value.

## TORQUE WRENCH SYSTEM

### OPERATING INSTRUCTIONS

#### STEP 1

- Make sure claw is in start position, as shown below in picture A.
- Align teeth on claw with splines on nut, as shown here in Step 1.
- Grip handle firmly and rotate clockwise to tighten nut.



#### STEP 2

- Rotate handle in a counter clockwise direction, as shown here in Step 2.
- Grip next set of splines with claw and rotate clockwise.
- Continue steps 1 and 2 until claw clicks over, as shown in Step 3 and picture B.

Proprietary design allows quick ratchet action.  
(Counter Clockwise Rotation)



#### STEP 3

- Snap claw back to its start position, as shown in picture A.
- Tighten nut one more time until claw clicks over.

**Note: Nut must be tightened twice with wrench.**



**PICTURE A**

START  
POSITION



**PICTURE B**

FINISH,  
CLICK OVER,  
POSITION



# Flare Link™

## WELDED SYSTEMS FABRICATED MANIFOLDS

Rapid turnaround from your concept to finished, welded manifold.

From concept to CAD model, fabrication and delivery, Fit-Line Global provides a turn-key solution for fast turnaround of customer-specified manifolds. With over 30 years of fluoropolymer and injection molding expertise, Fit-Line Global's proprietary, patented methods reduce the time needed to create custom manifolds for your application needs.

Manufactured from high purity virgin PFA resins in dedicated molds and process equipment, Fit-Line Global's custom manifolds are designed to maximize throughput of aggressive chemistry and ultra-pure water applications, they are available from 1/4 inch to 1-1/2 inch in diameter.

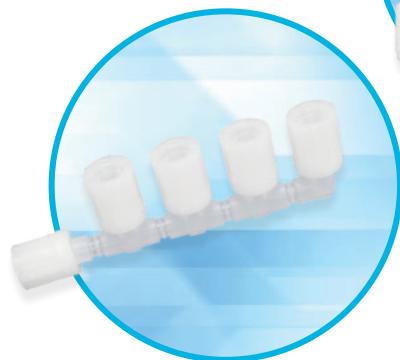
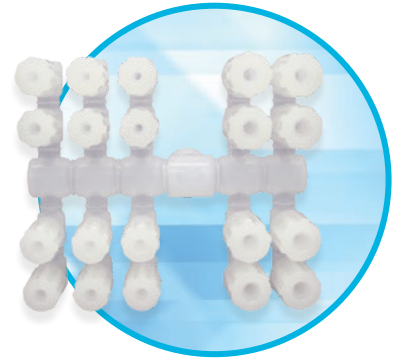



## U.S. DESIGNED & MANUFACTURED SOLUTIONS FOR FLUID PROCESSING APPLICATIONS



At Fit-Line Global, we engineer and supply the industry's most popular fitting configurations. That means when you need a fitting, it's available and ready to ship, allowing you to stay up and running and avoid costly delays.

From standard fittings and patented tube flaring systems, to customized designs that are developed, fabricated and tested in our state-of-the-art facility, Fit-Line Global has the expertise and the know-how to ensure you get the most reliable, dependable components delivered on time, all the time. At our core, we're a company of problem solvers.

Our employees are comprised of some of the best U.S. mechanical engineers, fabricators, senior toolmakers and process technicians with the curiosity, talent, insights and ideas to create the most advanced, dependable and leak-free solutions for all of your fluid processing needs.



## FULL PRODUCT AND PACKAGING TRACEABILITY. ZERO COMPROMISES.

Having our materials, manufacturing and packaging in a fully traceable, closed-source system ensures the highest level of protection, component quality and contamination control.

That's why Fit-Line Global employs our own proprietary cleaning and packaging processes—including our five stage component cleaning and rinsing procedure—all conducted in our very own Class 1000 Clean Room.

And when it comes to packaging, all of our fittings are double polyethylene bagged per SEMI F57-O622 standards. This will meet and exceed your exacting demands. Anything else simply won't do.



---

## DEDICATED TO YOU

Being an ISO 9001:2015 certified company means that we consistently provide products and services that meet customer and regulatory requirements and demonstrate continuous improvement. The certification acts as an assurance that our products are being manufactured in a facility that meets the requirements of ISO a well-known quality management system standard, and is reviewed yearly by an independent auditor.

## WARRANTY

Fit-Line Global warrants to the BUYER that any product sold will be free from defects in material or workmanship for a period of twelve (12) months from the date of shipment. If during the warranty period, the BUYER notifies Fit-Line Global of a defect, Fit-Line Global shall, at its option, repair or replace the defective material or workmanship. OTHER THAN AS EXPRESSLY STATED HEREIN, FIT-LINE GLOBAL MAKES NO OTHER WARRANTIES, EXPRESS OR IMPLIED, REGARDING THE PRODUCTS AND/OR SERVICES PROVIDED HEREUNDER, AND EXPRESSLY DISCLAIMS THE IMPLIED WARRANTIES OF NON-INFRINGEMENT, MERCHANTABILITY AND FITNESS FOR A PARTICULAR PURPOSE. The BUYER shall bear the cost of freight to and from Fit-Line Global's plant. BUYER agrees to accept the limits of liability as expressed in this statement to the exclusion of any and all provisions regarding statements of liability on the BUYER's own invoices, purchase orders and/or other documents.

## GOODS

All descriptions and illustrations contained in Fit-Line Global's catalog, brochures, price lists, website, advertisements and all specifications, drawings and any other documents contained therein submitted with any QUOTATION to BUYER or otherwise communicated to BUYER are intended merely to present a general idea of GOODS and SERVICES (GOODS) described therein and nothing contained in any of them shall form any part of the contract.



2901 Tech Center Drive, Santa Ana, CA 92705

Phone: (714) 549-9091

Email: [info@Fit-LineGlobal.com](mailto:info@Fit-LineGlobal.com)

Web: [Fit-LineGlobal.com](http://Fit-LineGlobal.com)